

Mountain Models
quality r/c kits

Spook-E™ Micro

Micro Nostalgic R/C Electric Airplane



Spook-E™ Specifications

Wingspan: 23.53 in.

Length: 15.66 in.

Wing Area: 100 sq. in.

Weight (Ready to Fly): 1.8 oz.

Wing Loading: 2.6 oz. / sq. ft.

Version 1.0, April 9, 2012

WARRANTY

Mountain Models guarantees this kit to be free from any defects in both material and workmanship at the time of purchase. This warranty does not cover ANY components or parts damaged by use or modification. In no case shall Mountain Model's liability exceed the original cost of the purchased kit. Mountain Models reserves the right to modify or change this warranty without notice.

LIABILITY RELEASE

In that Mountain Models has no control over the final assembly or material used for final assembly, no liability shall be assumed or accepted for any damage resulting from the use by the user of the final user-assembled product. By the act of using the user-assembled product, the user accepts all resulting liability.

If the buyer is not prepared to accept the liability associated with the use of this product, the buyer is advised to return the kit immediately in new and unused condition.

THIS PRODUCT IS NOT INTENDED FOR CHILDREN 12 YEARS OF AGE OR YOUNGER.

WARNING: This product may contain chemicals known to the State of California to cause cancer and or birth defects or other reproductive harm.

PRODUCT SUPPORT

This product has been designed to function properly and perform as advertised with the SUGGESTED power system, speed control, and servos, as described in advertisements and in this manual. We do NOT support, nor can Mountain Models assist in determining the suitability or use with any other electronics or hardware not recommended by Mountain Models.

For the proper electronics to complete this model, replacement parts, and product assembly questions, please contact Mountain Models online at www.MountainModels.com

Thank you for purchasing the Mountain Models Spook-E™ Micro. The Spook-E™ Micro is a micro model designed with influence from the famous Spook, a classic vintake plane, to bring back that nostalgic feeling of yesteryear, in an indoor electric package. The 23.5 inch Spook-E™ Micro is a super easy to build and easy enough for a beginner to learn how to fly, with some friendly help.

The Spook-E™ was designed using a state of the art 3D CAD package, to allow for exceptional interlocking parts design and fit. 3D design also allows us to provide clearer assembly images, without having to use photos.

The Spook-E™ is built from self-jigging interlocking laser cut balsa and plywood parts. It's like a 3D jigsaw puzzle with instructions. Although not needed for building, full size plans are included for reference. If the instructions are read before hand and followed during the build, the Spook-E™ can be built up and ready to fly in only a few evenings.

We think you'll like the Spook-E™ and look forward to any feedback you might have.

Thank you,
Brian Eberwein

Mountain Models
2935 N Lynndale Drive
Appleton, WI 54914
www.mountainmodels.com

Phone: 920.840.6036

Before You Begin

Check to make sure that all of your parts are there and in good shape.

Parts List

Number in Kit	Description of Part
Bundled Parts	
1	Laser Cut Parts Sheets (6 Sheets)
2	Plan Sheets (11" x 17")
1	These instructions of course!
Metal (on the back of the wood bundle)	
1	0.020 x 18" Wire
1	0.020" x 12" Wire
1	1/32" x 12" landing gear wire
Bagged Parts	
2	Wheels
1	1/16" Aluminum Tube
1	1/16" x 1" Shrink Tube
1	1/8" x 2-1/2" Dowel
6	#16 Rubber Bands

Building Materials and Tools You Will Need

- Smooth and FLAT work surface
- Wax paper or clear plastic wrap to protect the work surface
- Thin Cyanoacrylate (CA) glue
- Hobby knife with #11 blades
- Needle nose pliers
- Wire cutters
- Sanding block, 320 to 400 grit sandpaper
- Covering Iron

Finishing Materials You Will Need

- SoLite Covering (Do NOT use heavier covering!!!!!!!!!!!!!!)
(You can use a light weight tissue covering instead of SoLite)
- Double-Sided Foam Tape
- Hinge Tape (DuBro or Similar)
- Velcro to Mount Battery

Electronics You Will Need

- Power: ParkZone Motor/Gearbox (PKZ3624) for UM P-51/Sukhoi
- Prop: EFL9051 Ultra Micro 130mm x 70mm
- RX/ESC/Servo: ParkZone 'Vapor' PKZ3351 or Spektrum AR6400
- 1S-130 mAh LiPo

General Building Tips

- **READ THE INSTRUCTIONS** all the way through and study the plans **BEFORE** starting any work on the model.
- **PRE-SANDING: BEFORE** removing any parts from the balsa sheets, use a sanding block with 320 grit sandpaper and lightly sand the back of the balsa sheets. Our balsa suppliers have been sending us wood that is over sized, so sanding the backs of the balsa sheets reduces the thickness just slightly and removes any charring from the laser cutting process.
- Tape the plans to your nice clean work surface and cover it with wax paper or plastic wrap. You want to keep your work surface clean and not glue the parts to the plans, right?
- Balsa is a lightweight and fragile wood, so you do need to be careful with it; however, you will also need to use a little bit of force to make everything fit properly, so don't be too timid.
- Do not remove any pieces from the balsa sheets until they're ready to be used. That way, parts won't get mixed up or disappear.
- Do NOT glue anything until told to do so.
- Join all of your pieces using thin CA (Cyanoacrylate) glue, unless we tell you otherwise. In general, only a small amount of CA is necessary to glue parts together.
- Don't over force your pieces together. If they aren't fitting together properly, make sure you have the right pieces and that they are oriented correctly. If needed, you can lightly sand the part to fit after making sure it is the correct part and oriented correctly. On balsa "tabs", you can "pinch" the wood with your fingers to get them to fit in slots. (The tabs might be tighter some times, due to tolerances in wood thickness)
- If you want to remove the charred edges caused by the laser cutting process, lightly dampen a cloth with bleach and gently rub the affected areas. Removing the char will not increase the strength but will make it look better. It also keeps that dark edge from showing under the lightweight coverings. You can also remove it by LIGHTLY sanding with 400 grit sandpaper.

1. Join the $\frac{1}{16}$ " balsa W1 and W1A parts together with thin CA, to make the main spar, W1.
2. Join the $\frac{1}{16}$ " balsa W2 and W2A parts together with thin CA, to make the rear spar, W2.
3. Glue the plywood W1R spar reinforcements onto W1, with thick CA. BE SURE to align them properly, as shown on the plans.
4. Glue the plywood W2R spar reinforcements onto W2, with thick CA. BE SURE to align them properly, as shown on the plans.

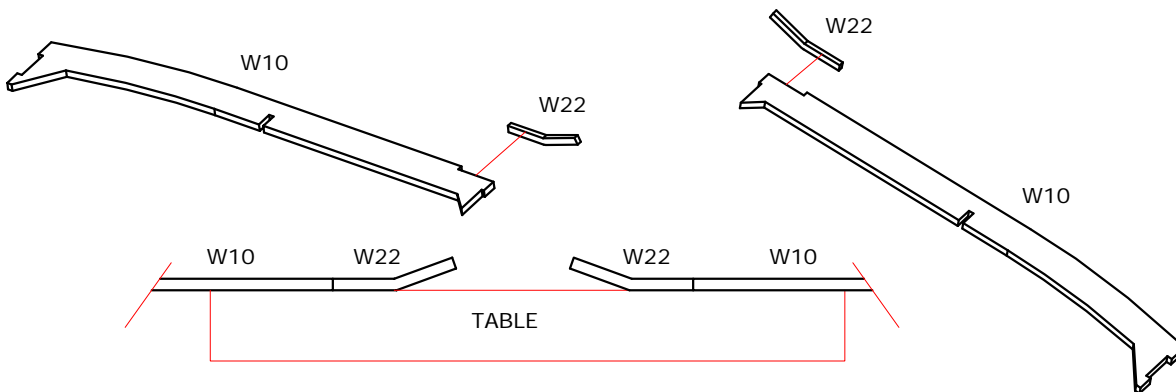
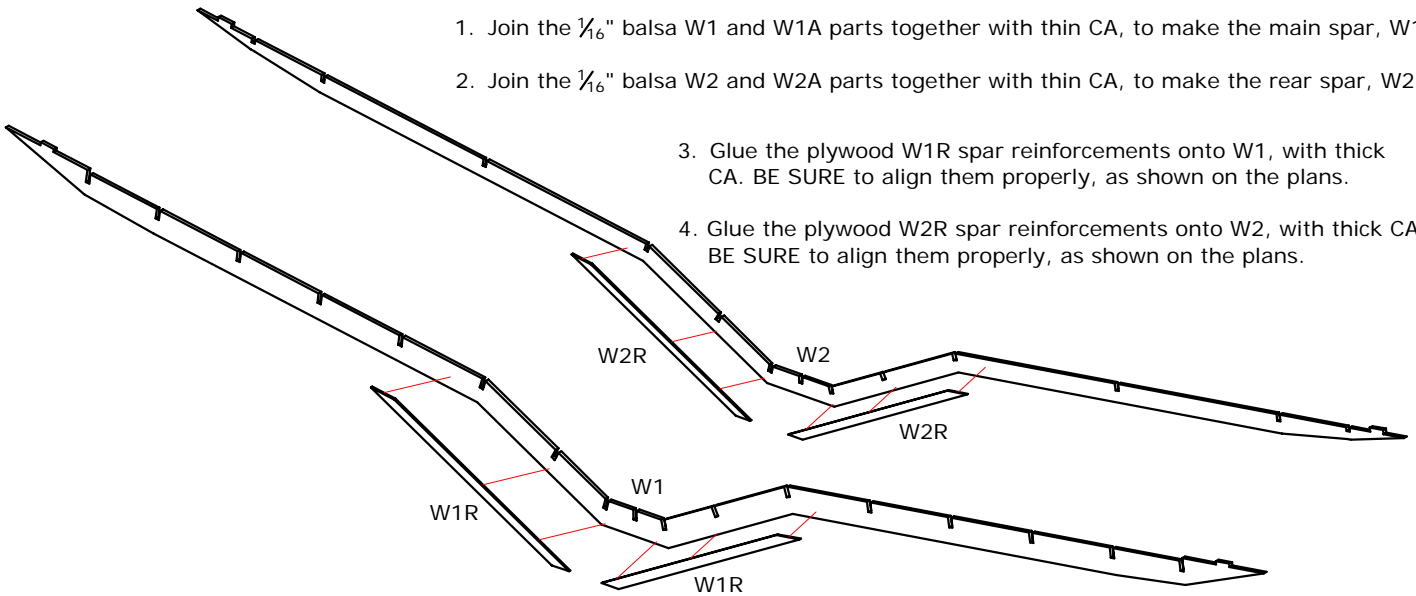

5. Glue the plywood W22 parts onto the $\frac{3}{32}$ " balsa W10 parts, making a LEFT and RIGHT as shown, with thick CA. Place the "dirty" side of W10 "up".

6. READ THIS STEP!! Glue the $\frac{3}{32}$ " balsa W9 parts onto the W10/W22 assembly, with thick CA. BE SURE to align them properly, and make a LEFT and RIGHT. THE ENGRAVED TEXT ON W9 goes AWAY from the W22 parts.

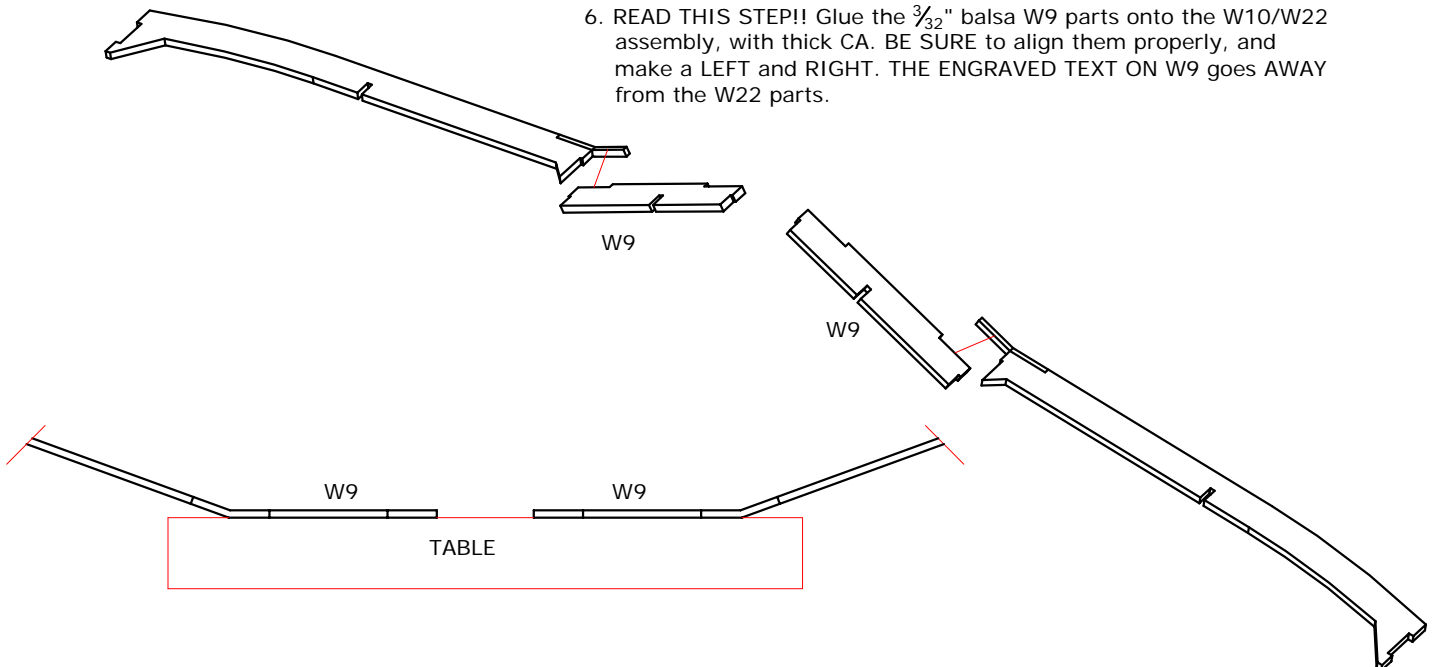

7. Glue the plywood W21 brace onto one of the assemblies from the previous step, with the long part of the W10/W9 assembly hanging off the table.

8. Glue on the other assembly, as shown.

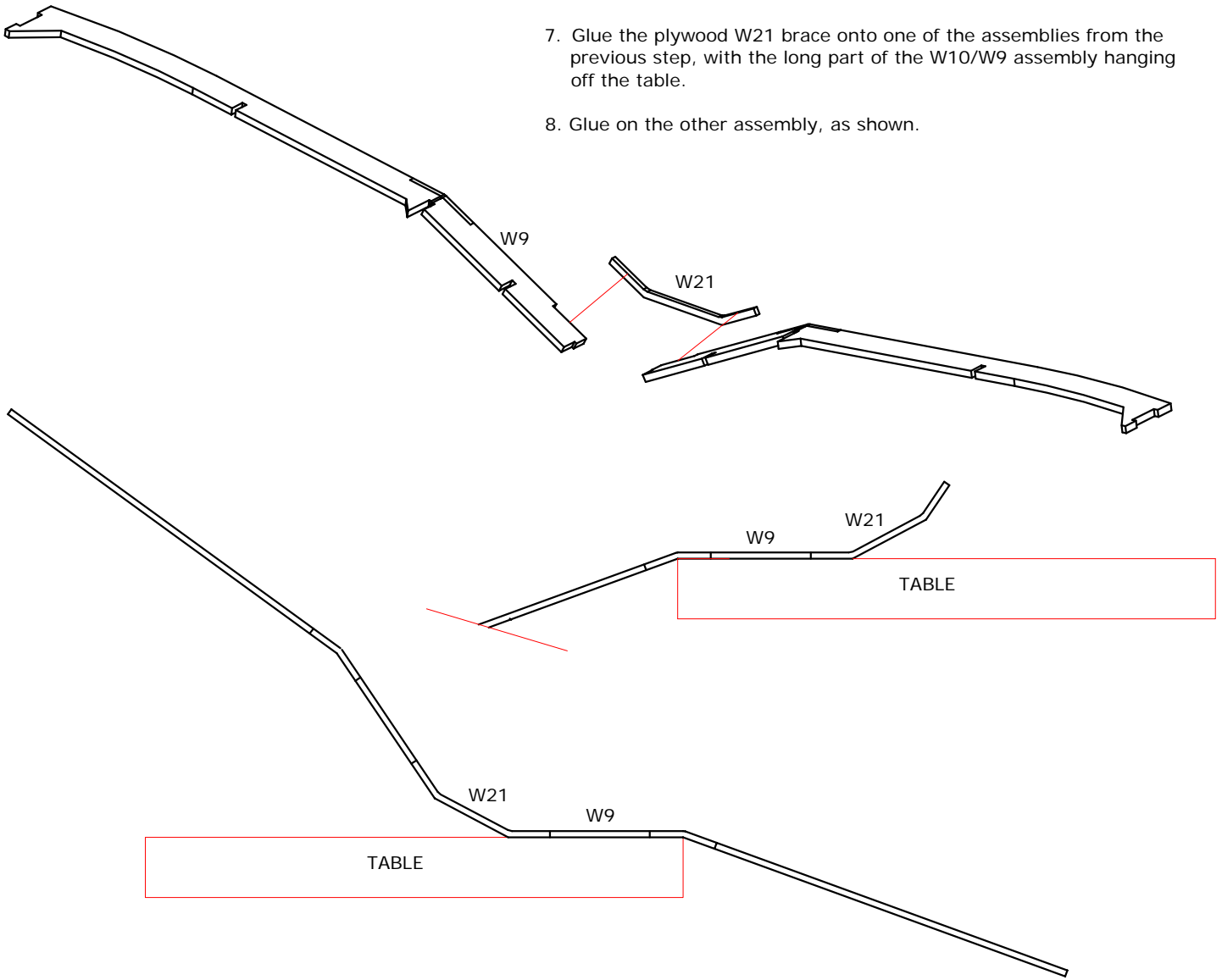

9. Glue the $\frac{3}{32}$ " balsa W8 part onto the W21 brace with thick CA.

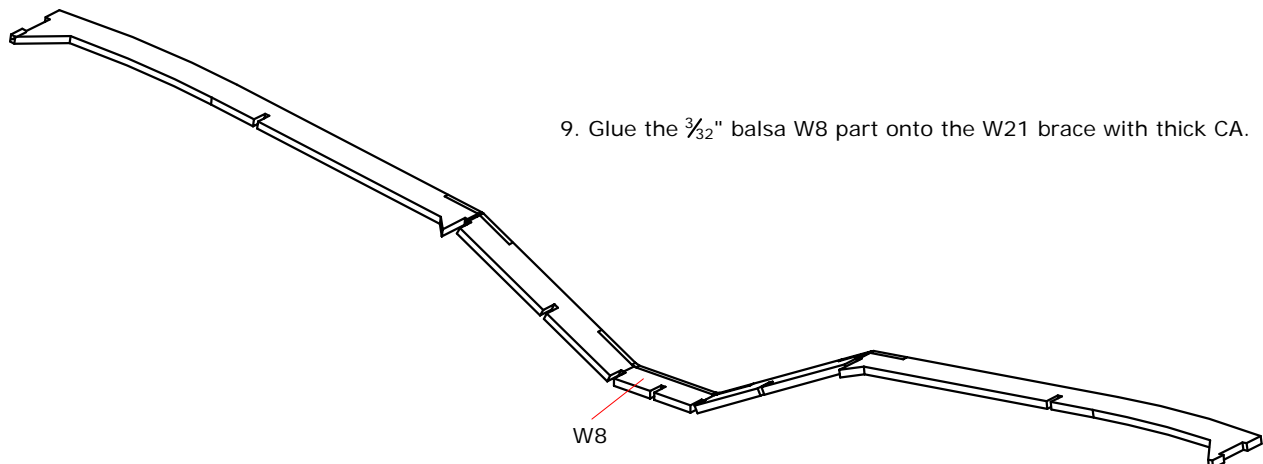

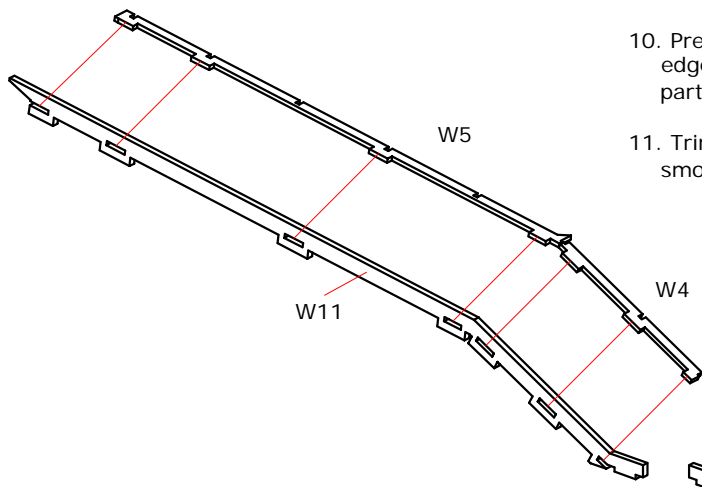

10. Press the $\frac{1}{16}$ " balsa W4 and W5 parts into the $\frac{3}{32}$ " balsa leading edge W11 parts, as shown. Secure with thin CA, making sure the parts are fully inserted and at a right angle to each other.
11. Trim off the bottom "tabs" on W11, so the bottom surface is smooth.

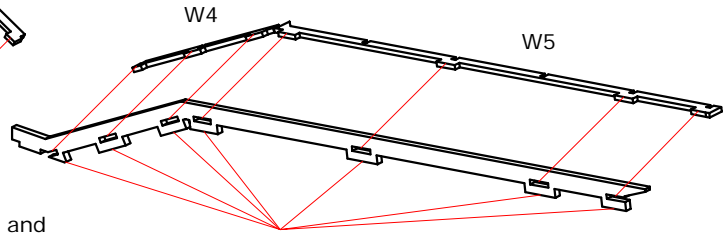

Trim off tabs,
after assembly.

12. Slide the $\frac{1}{16}$ " balsa W12 and W13 ribs onto the spars and into the trailing edge assembly. Tack glue with thin CA, making sure everything is fully inserted and aligned.

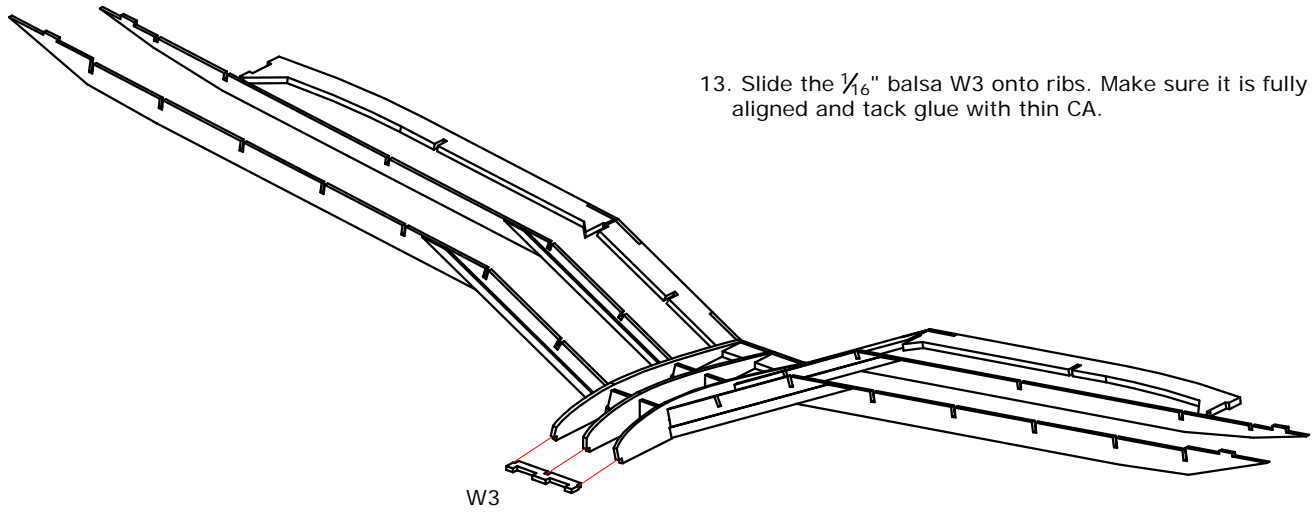
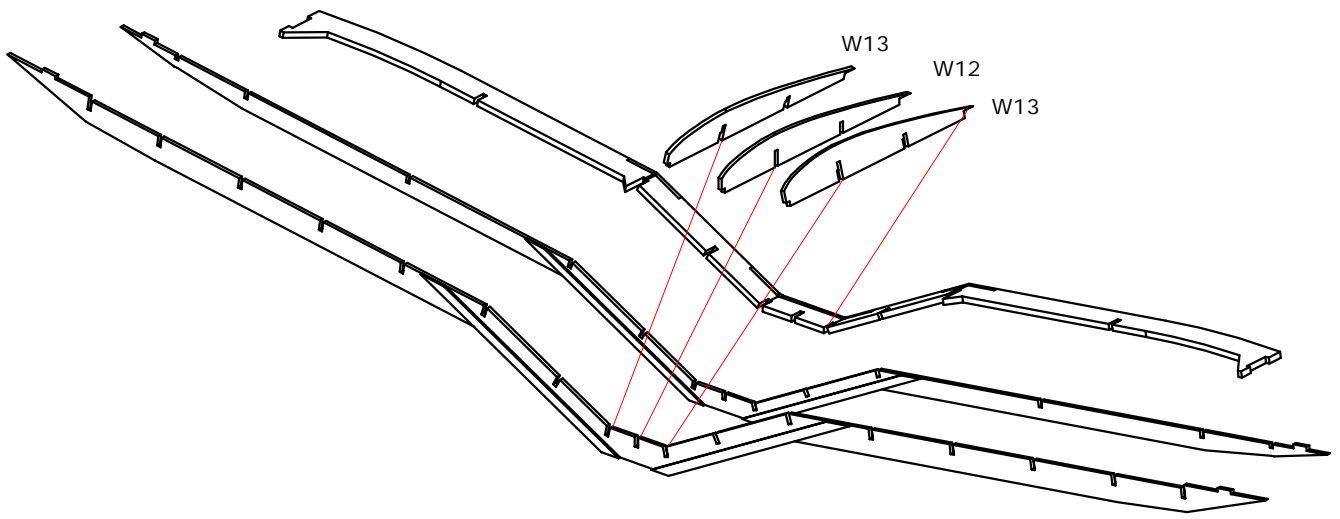

13. Slide the $\frac{1}{16}$ " balsa W3 onto ribs. Make sure it is fully aligned and tack glue with thin CA.

14. Slide the leading edge assembly onto W3. Make sure everything is aligned and tack glue it with thin CA.

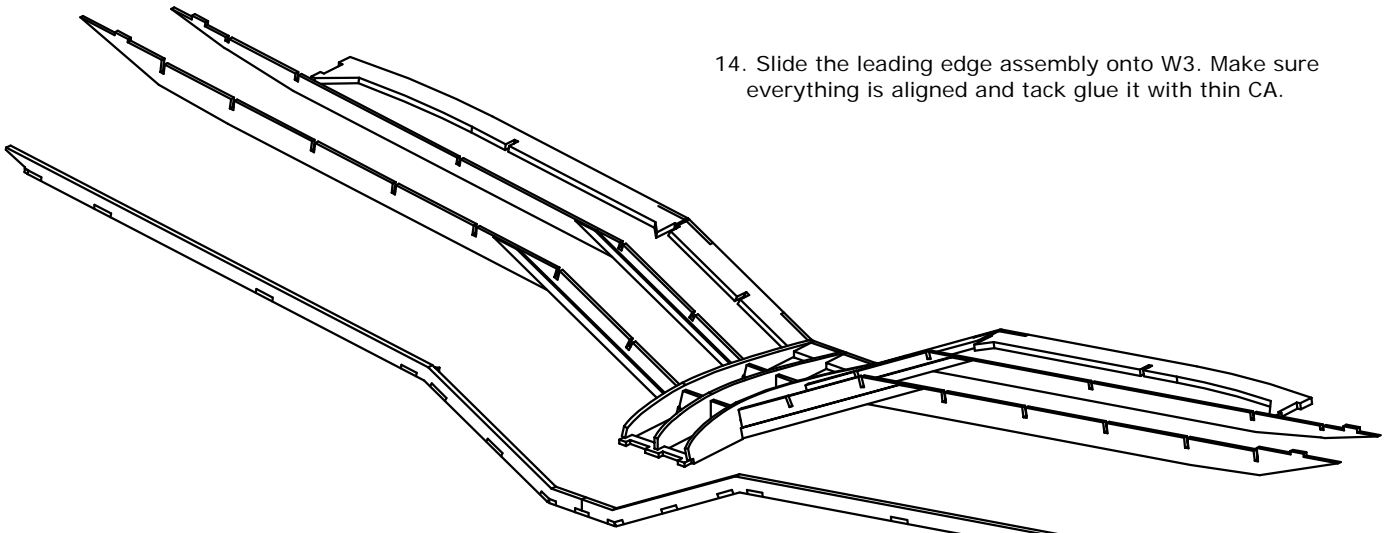

15. Slide the $\frac{1}{16}$ " balsa W14 and W15 ribs in place on the LEFT wing. With the outer wing panel hanging off the table, tack glue them with thin CA, making SURE that they are fully inserted into the spars, trailing edge, and leading edge assembly.

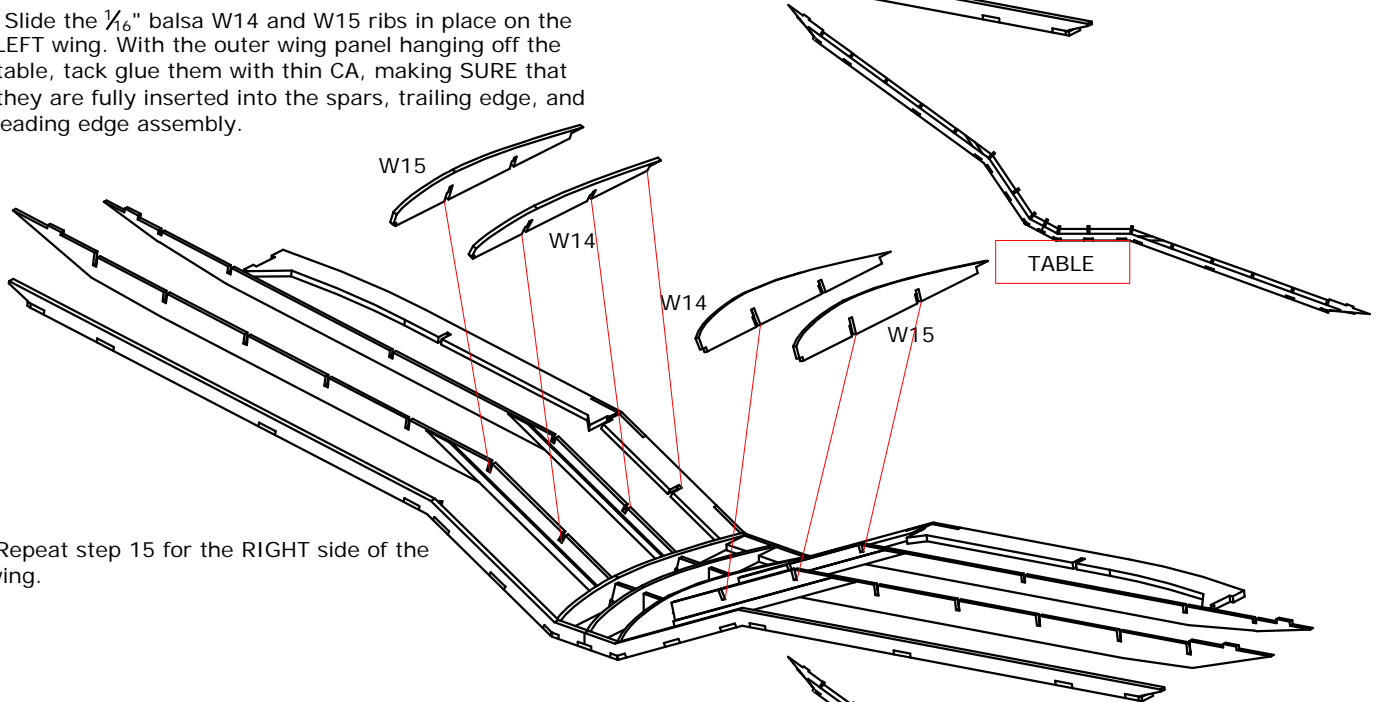

16. Repeat step 15 for the RIGHT side of the wing.

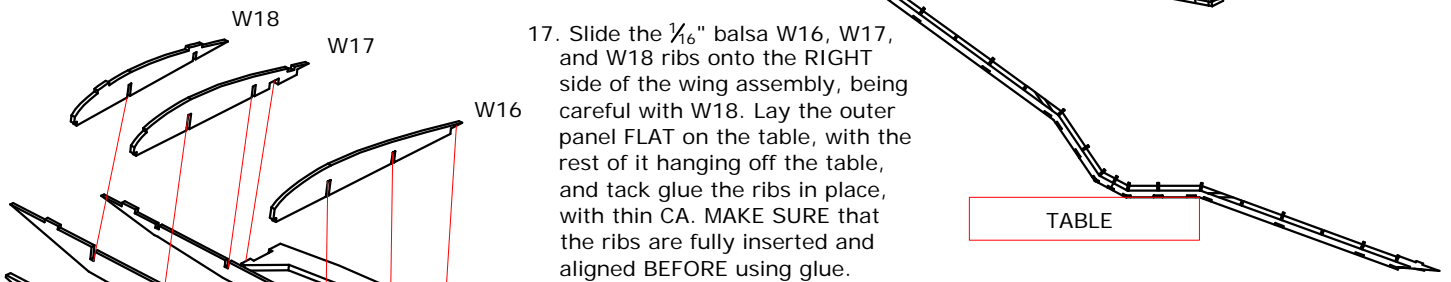

17. Slide the $\frac{1}{16}$ " balsa W16, W17, and W18 ribs onto the RIGHT side of the wing assembly, being careful with W18. Lay the outer panel FLAT on the table, with the rest of it hanging off the table, and tack glue the ribs in place, with thin CA. MAKE SURE that the ribs are fully inserted and aligned BEFORE using glue.

18. Repeat step 17 for the LEFT side of the wing.

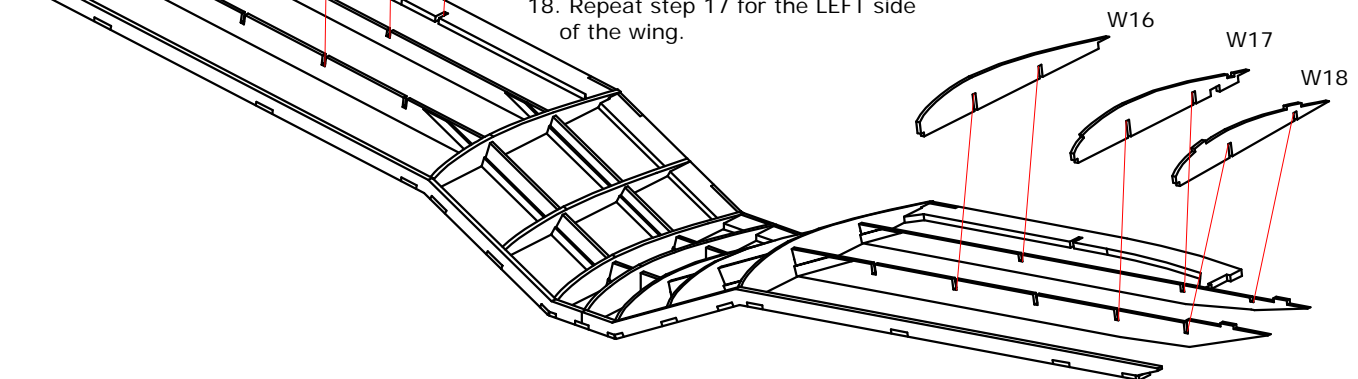

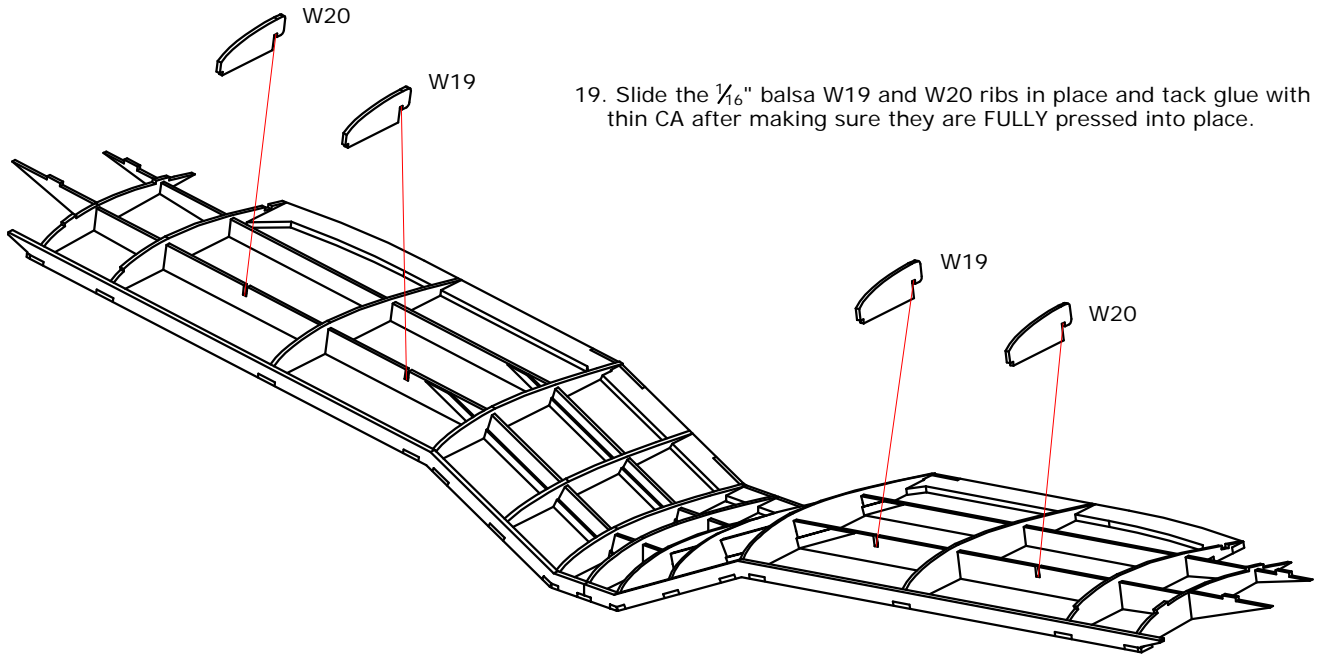

19. Slide the $\frac{1}{16}$ " balsa W19 and W20 ribs in place and tack glue with thin CA after making sure they are FULLY pressed into place.

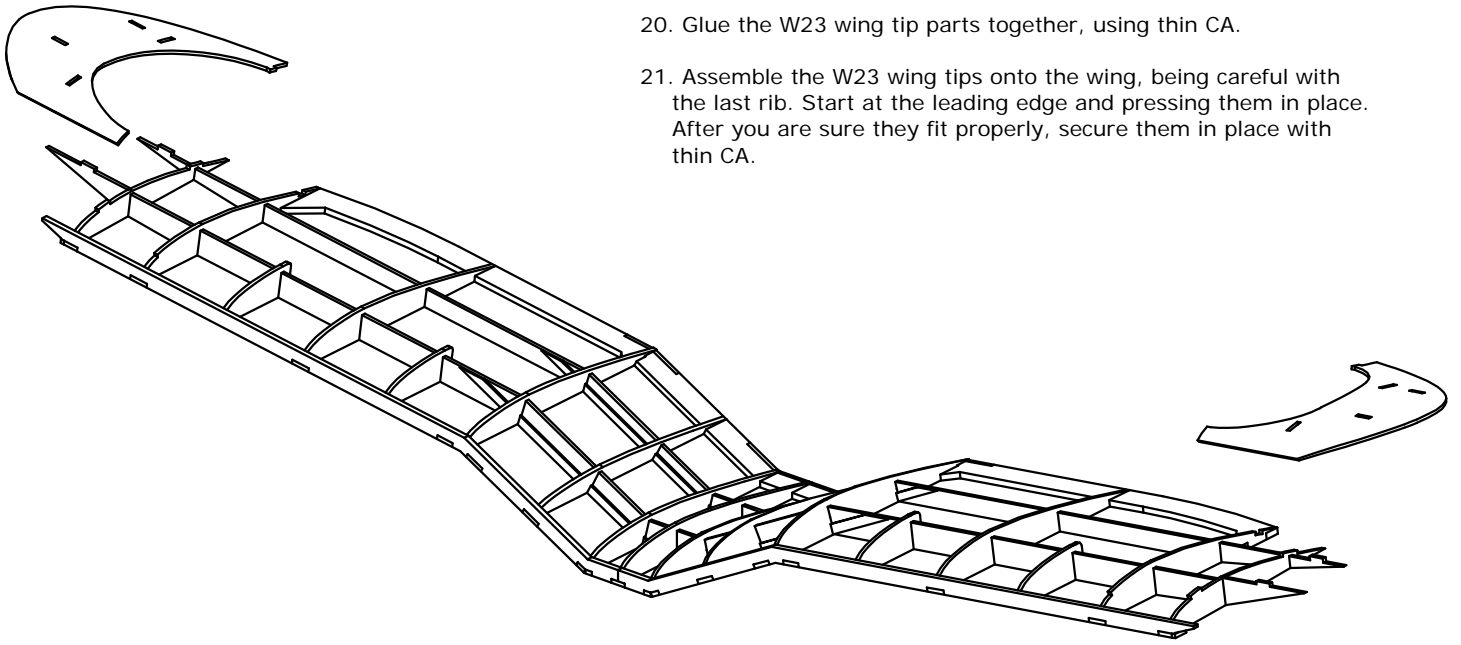

20. Glue the W23 wing tip parts together, using thin CA.

21. Assemble the W23 wing tips onto the wing, being careful with the last rib. Start at the leading edge and pressing them in place. After you are sure they fit properly, secure them in place with thin CA.

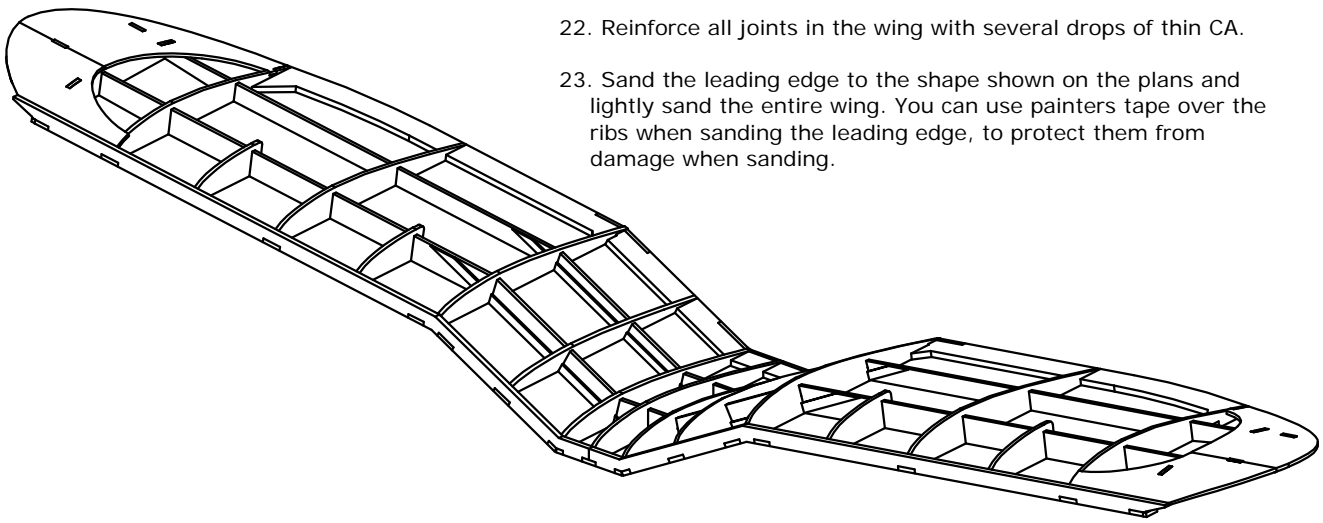

22. Reinforce all joints in the wing with several drops of thin CA.

23. Sand the leading edge to the shape shown on the plans and lightly sand the entire wing. You can use painters tape over the ribs when sanding the leading edge, to protect them from damage when sanding.

24. Glue in the W19, W20, and W21 parts into the fuselage sides, using thin CA.

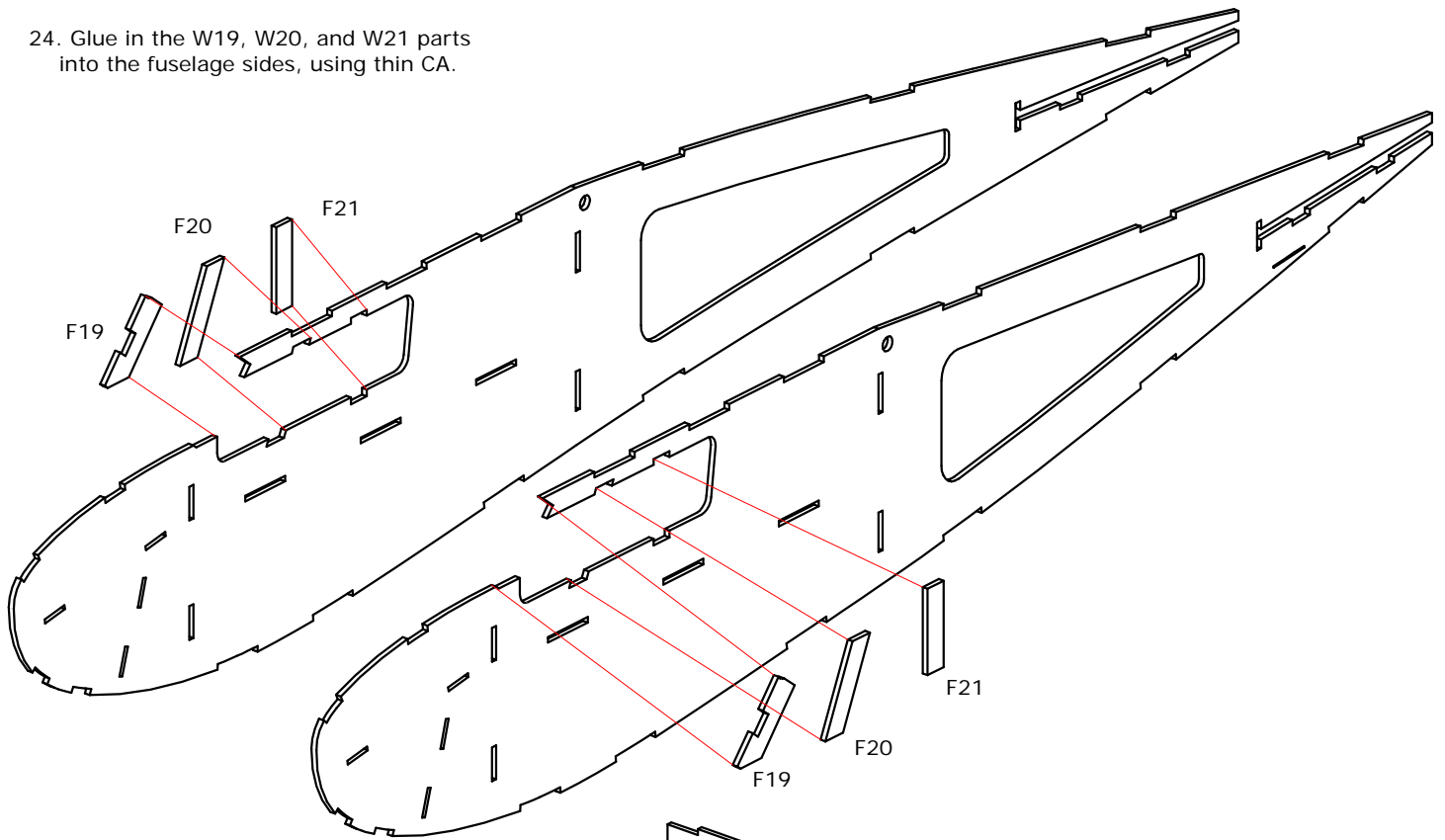

25. Press the F1 crutch into the F2 and F3 formers. Do NOT glue them yet.

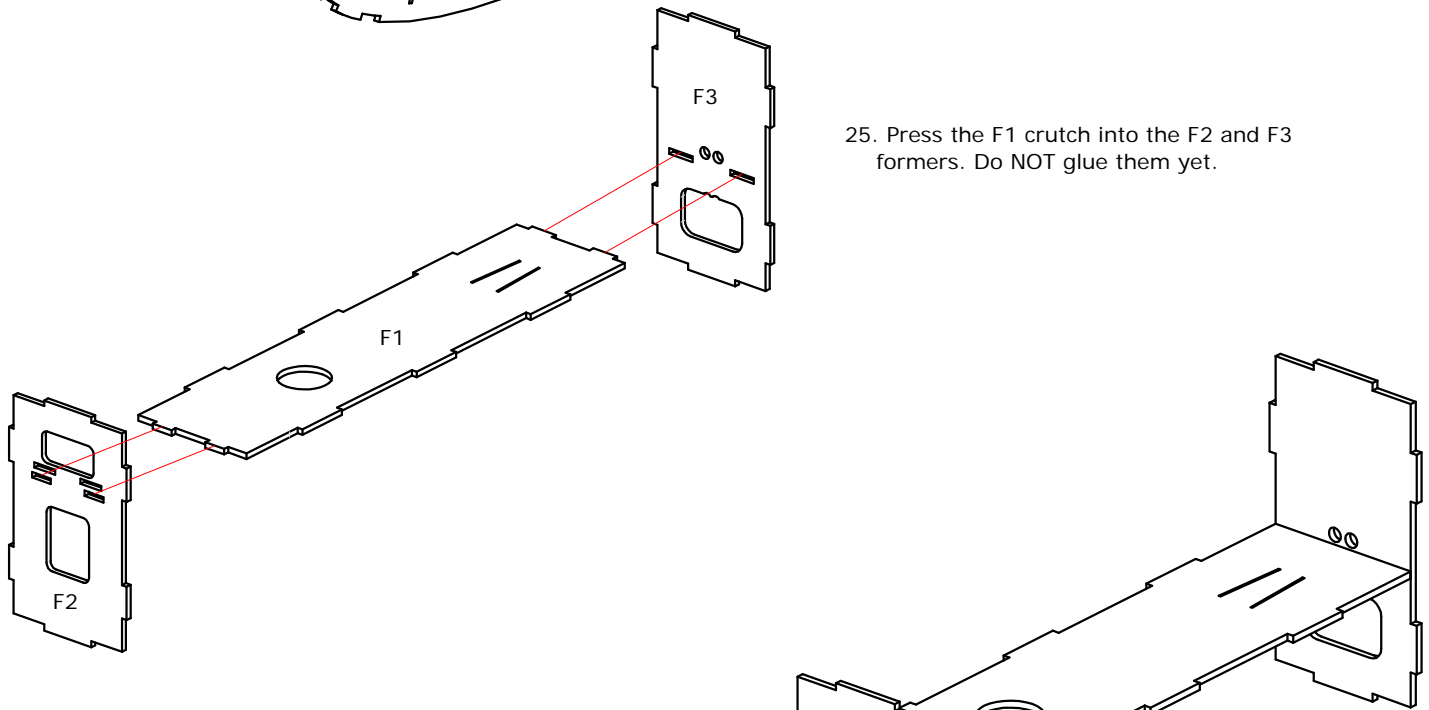

26. Press the plywood F4 motor mount into the F2 former, but do NOT glue it yet. MAKE SURE you install it with RIGHT THRUST (Engraved text facing UP), as shown on the plans. If you glue it in upside down, your plane will NOT fly properly!!!

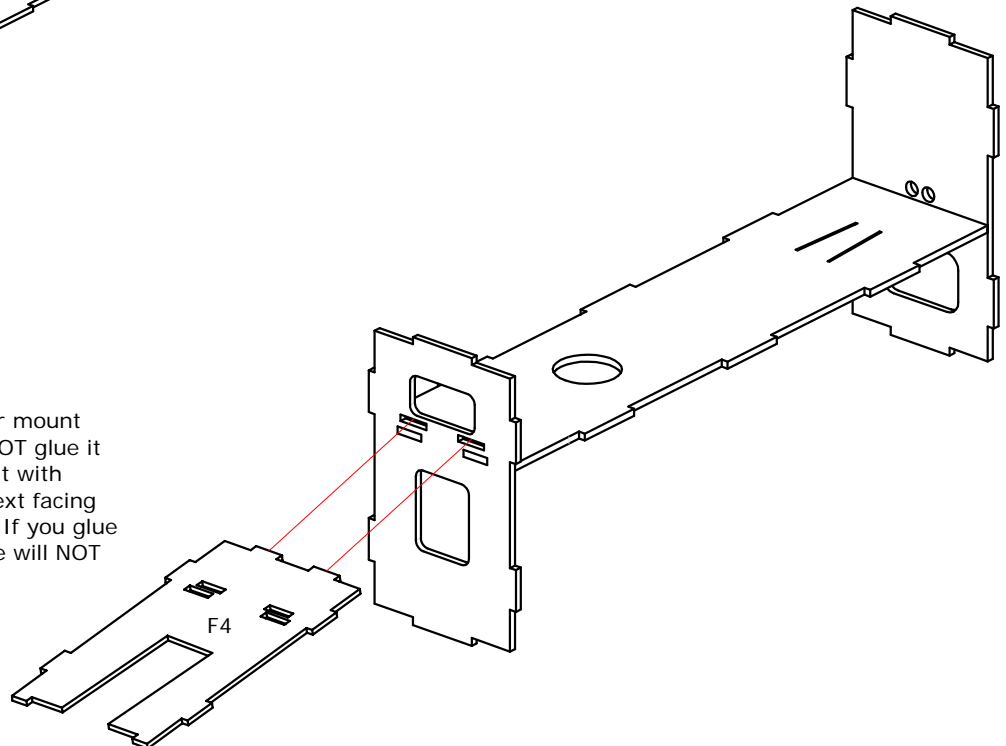

27. Press the crutch assembly into the right fuselage side. Do NOT glue it.

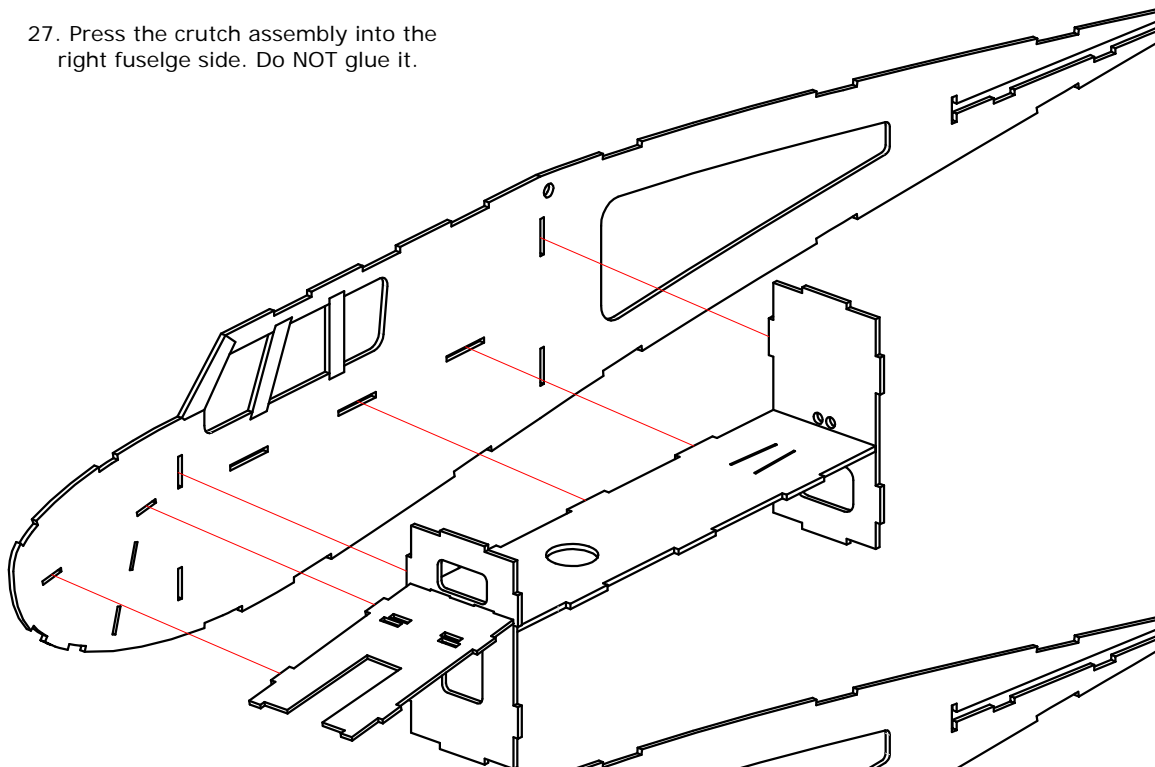

28. Press the plywood F6 and F7 landing gear formers into the crutch and fuselage side. Do NOT glue anything yet.

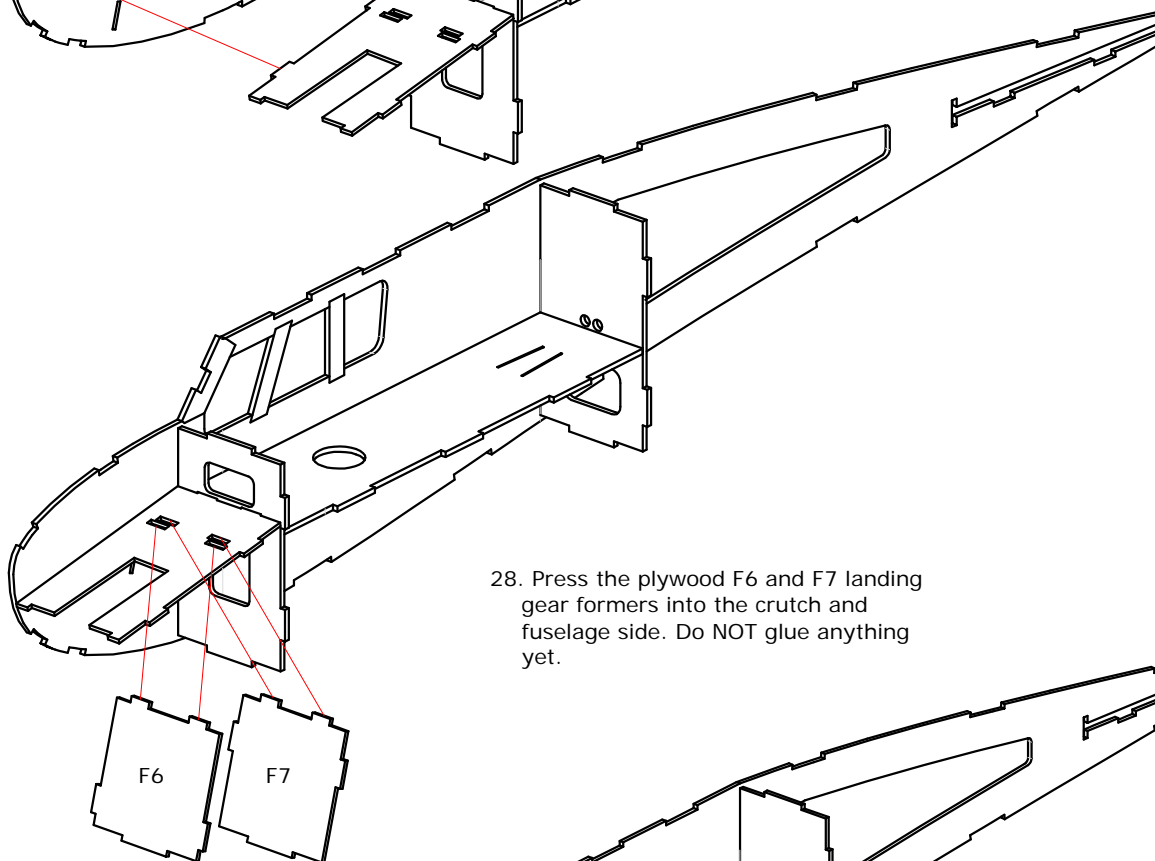

29. Press the crutch/fuselage assembly into the left fuselage side. Make sure everything is fully pressed together and the fuselage is square. Secure the joints with thin CA.

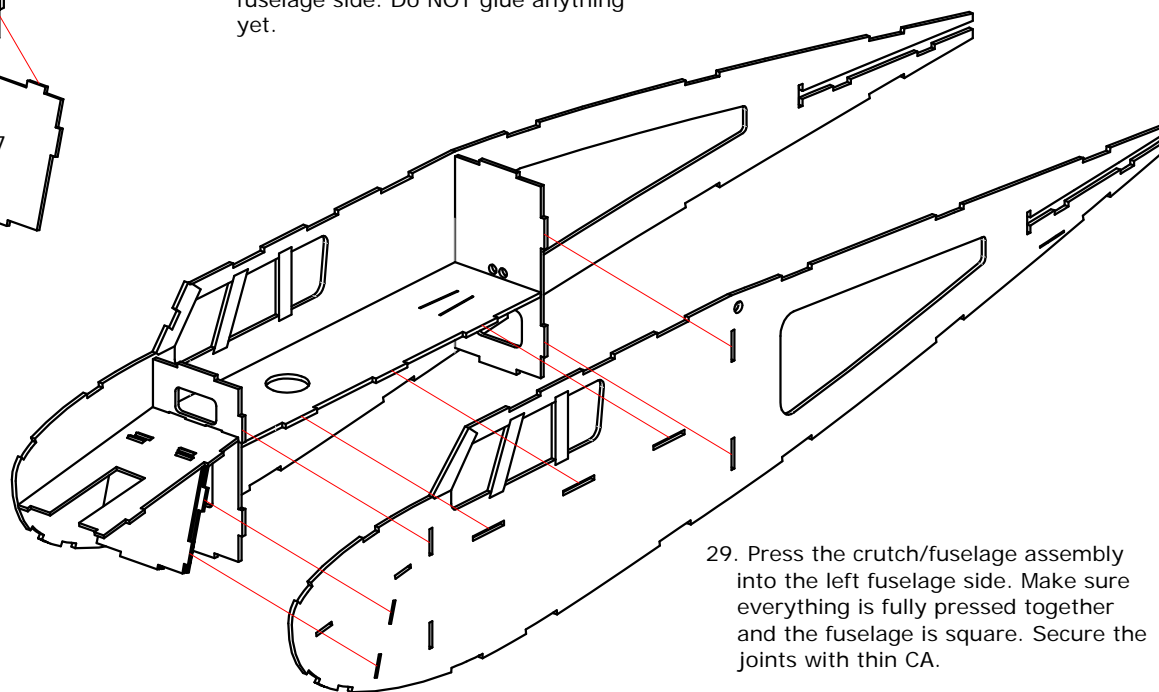

30. Glue in the F22 and F23 doublers on the INSIDE of the fuselage front, as shown, using thick CA.

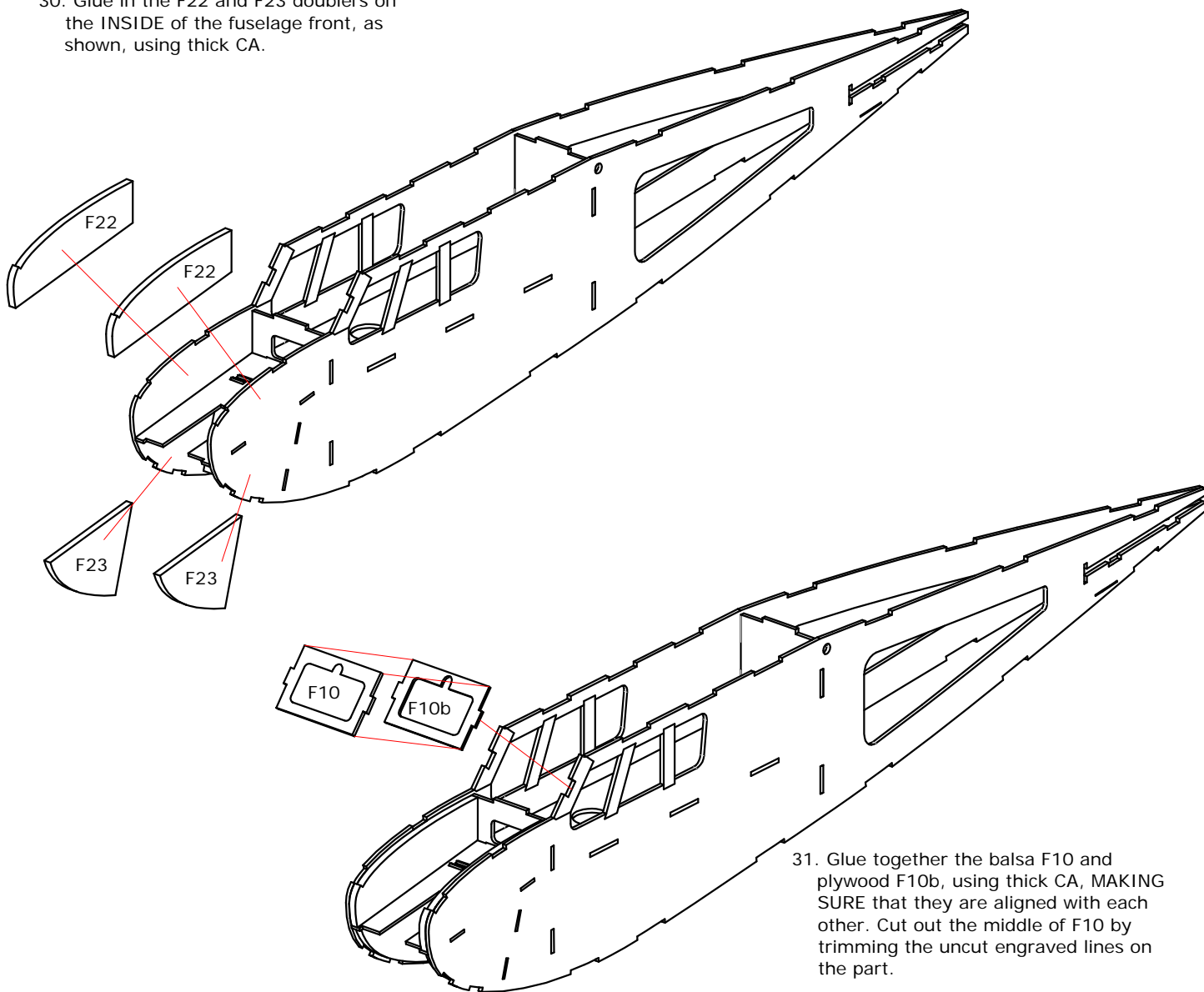

31. Glue together the balsa F10 and plywood F10b, using thick CA, MAKING SURE that they are aligned with each other. Cut out the middle of F10 by trimming the uncut engraved lines on the part.

32. Press the F10 part into the fuselage, as shown. Secure in place with thin CA.

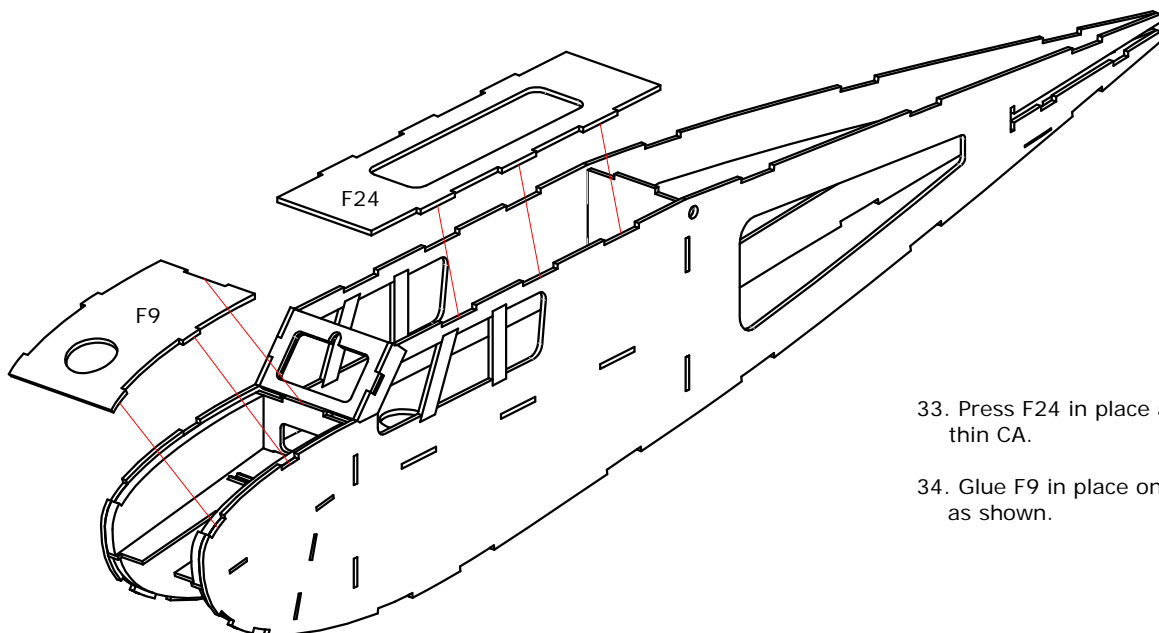

33. Press F24 in place and secure with thin CA.

34. Glue F9 in place on the fuselage front, as shown.

35. Press the plywood F17 in place, as shown. Make sure it is fully pressed in place and secure it with thin CA.

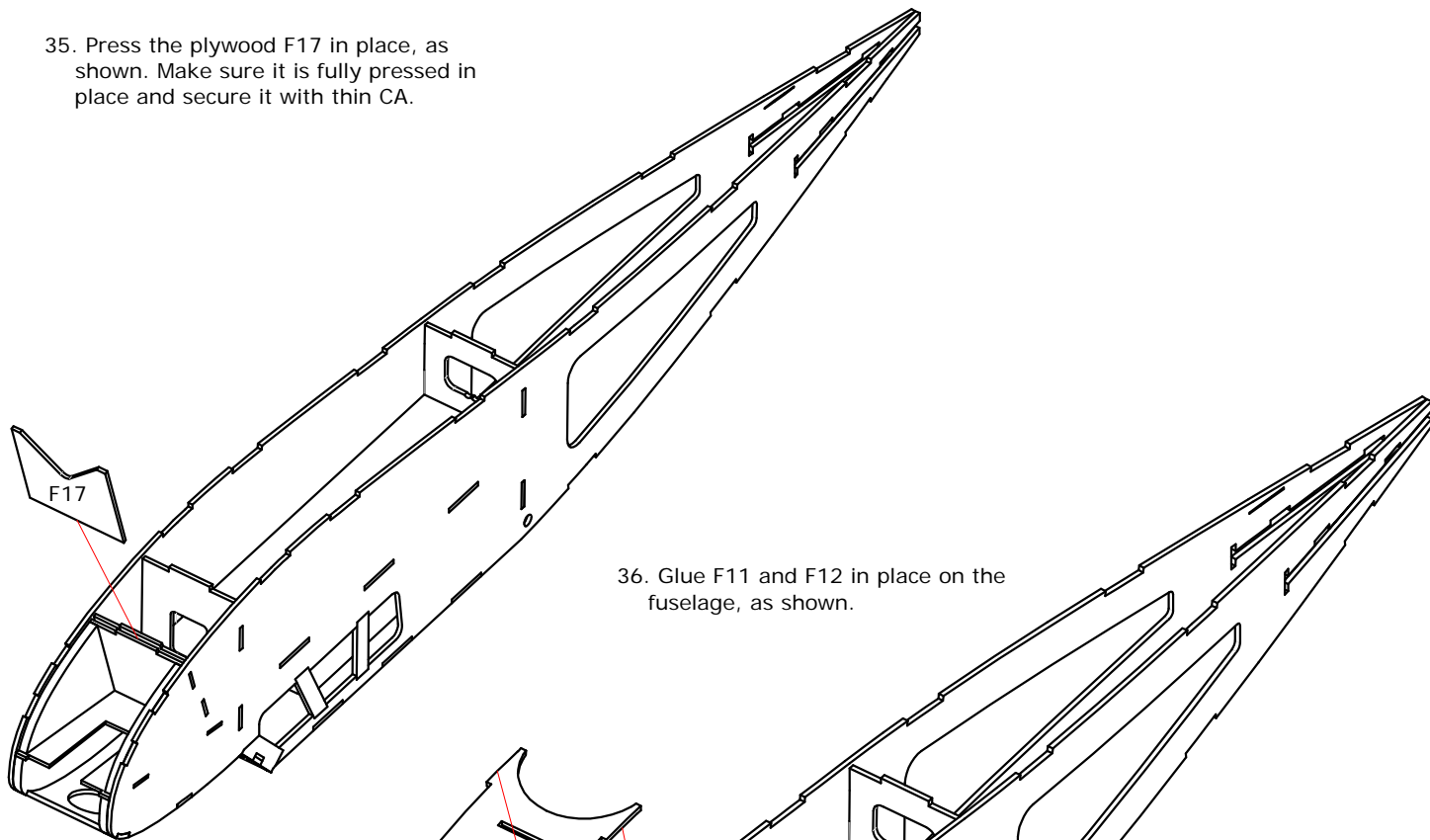

36. Glue F11 and F12 in place on the fuselage, as shown.

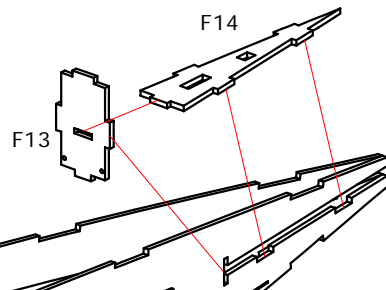
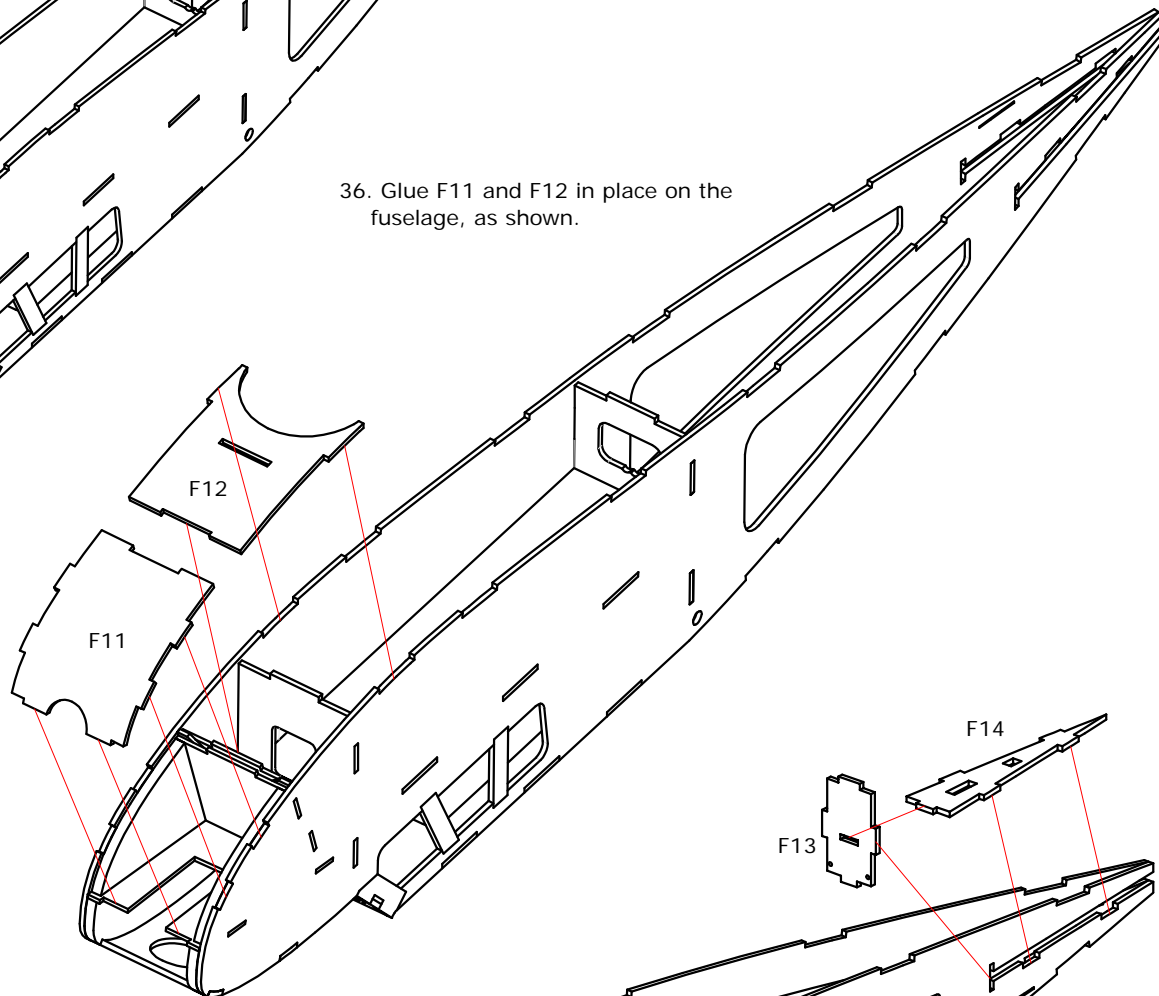

37. Press F14 into F13, but Do NOT glue them together yet.

38. Press the F13/F14 in place in the fuselage, as shown above, and on the plans. MAKE SURE the rear of the fuselage sides are lined up, and glue the F13/F14 parts in place, with thin CA.

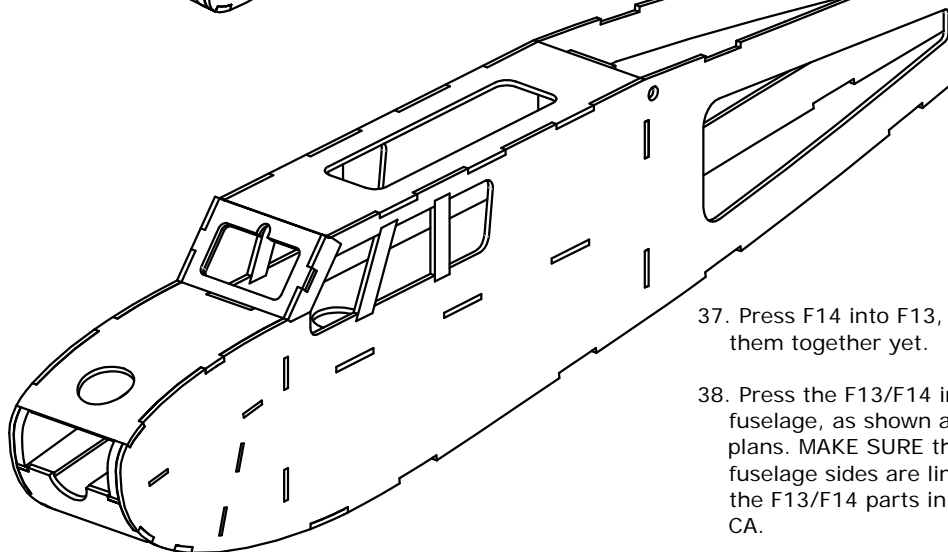

39. Press F15 in place and glue with thin CA, AFTER making sure it is fully inserted in the fuselage sides.

40. Press F16 in place and glue with thin CA AFTER making sure it is fully inserted in the fuselage sides.

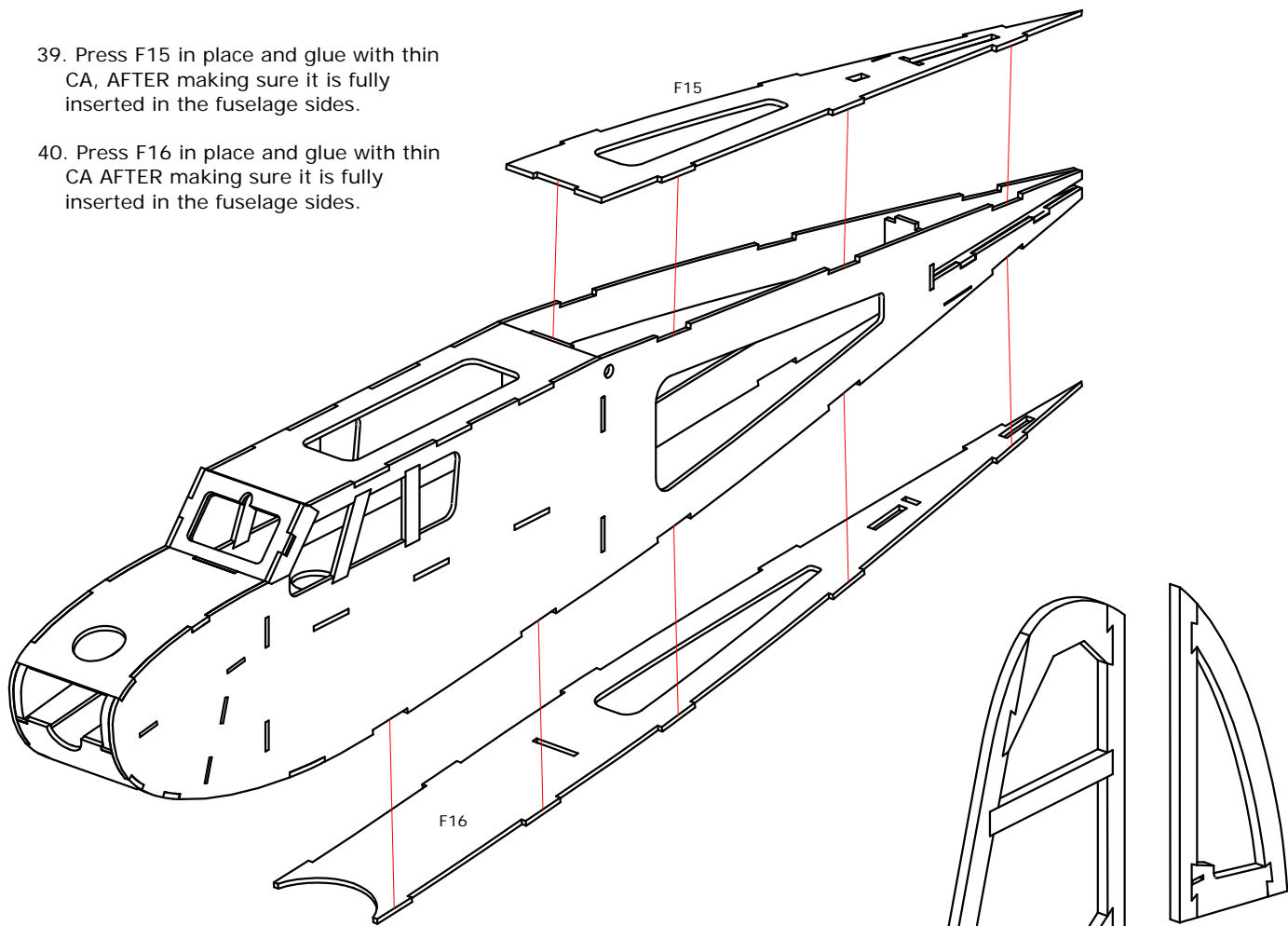

41. Glue the horizontal stab, elevator, vertical fin, rudder, and skid with thin CA.

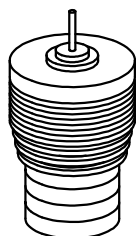
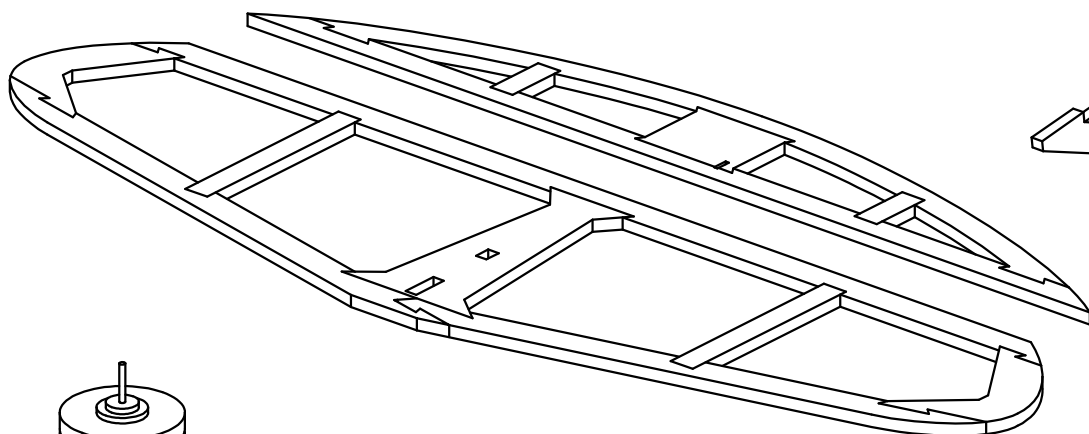

42. Assemble the dummy engine, as shown on the plans, using thick CA to glue the parts together.

43. Sand the entire airframe, rounding corners of the front of the fuselage, and finishing the airframe with 320 grit sandpaper.

44. Bevel the elevator and rudder, as shown on the plans.

45. Paint the dummy engine, as desired.

46. Cover the airframe with So-Lite or tissue. Do NOT use heavier coverings such as MonoKote, UltraCote, UltraCote Light, Solarfilm, or the cheap Chinese coverings. Heavier coverings will warp the structure and be WAY too heavy for this lightweight plane.

47. Insert the horizontal stab through the slot in the fuselage, but do NOT glue it in place yet.

48. Insert the vertical fin through the slot that goes through the fuselage top, through the stab, and into the stab support in the fuselage. Move the stab slightly to get evrything aligned and pressed in place.

49. MAKE SURE that the stab is paralell to the fuselage and that the vertical fin is at a 90 degree angle to the horizontal stab. Secure the parts with several small drops of thin CA.

50. Glue the skid in place with thick CA, making SURE that it is at a 90 degree angle to the bottom of the fuselage.

51. Fold the windshield along the dashed cut lines, and glue it onto the fuselage, using several SMALL drops of thick CA on the fuselage sides.

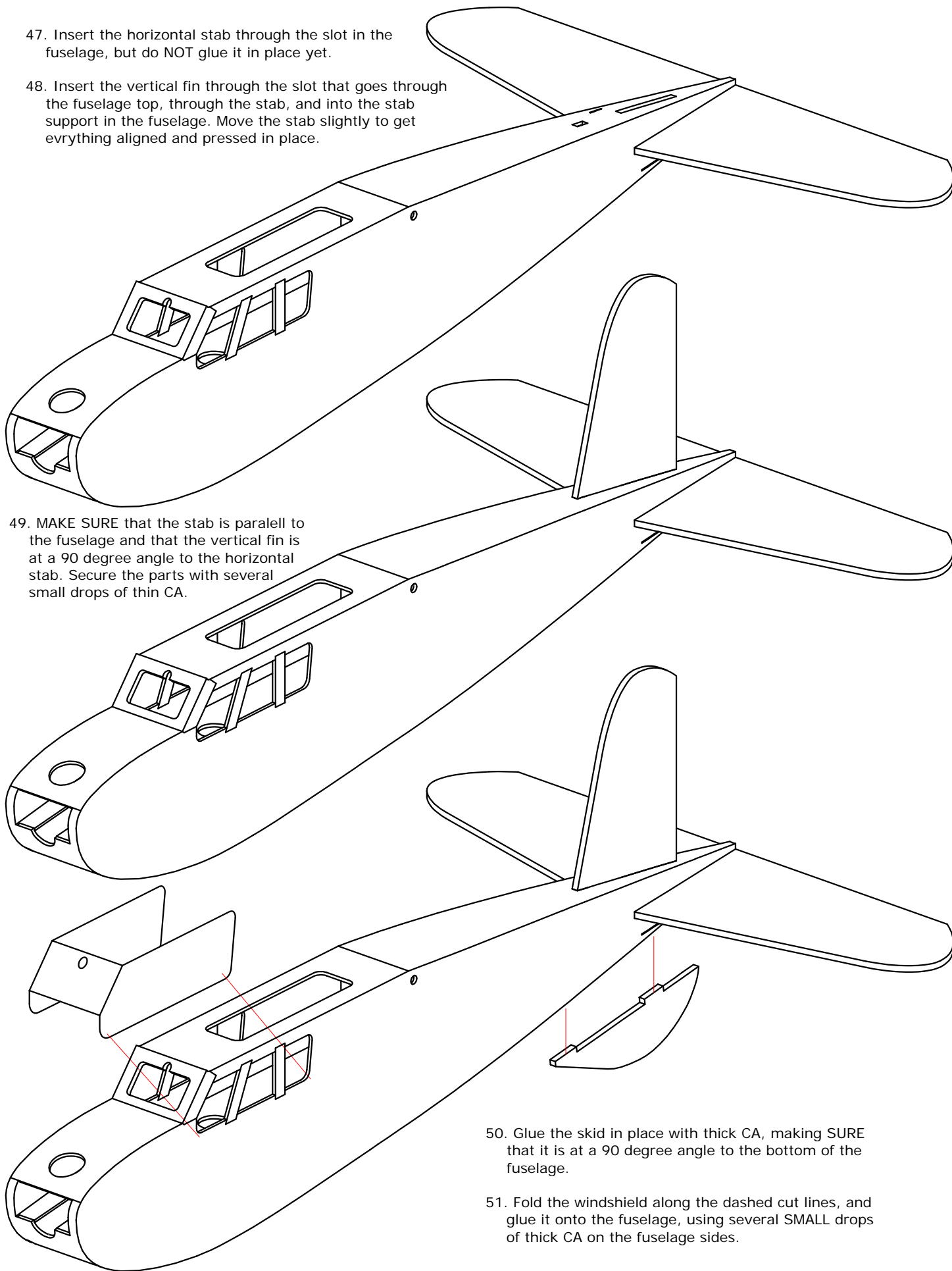

52. Hinge the elevator to the horizontal stab, using hinge tape, as shown on the plans. There should be a small (1/64") gap between the parts. Do the same for the rudder and vertical fin.

53. Insert the motor through the hole in the fuselage top front. It should go through the hole by about 1/8". Secure it in place with several small drops of thin CA.

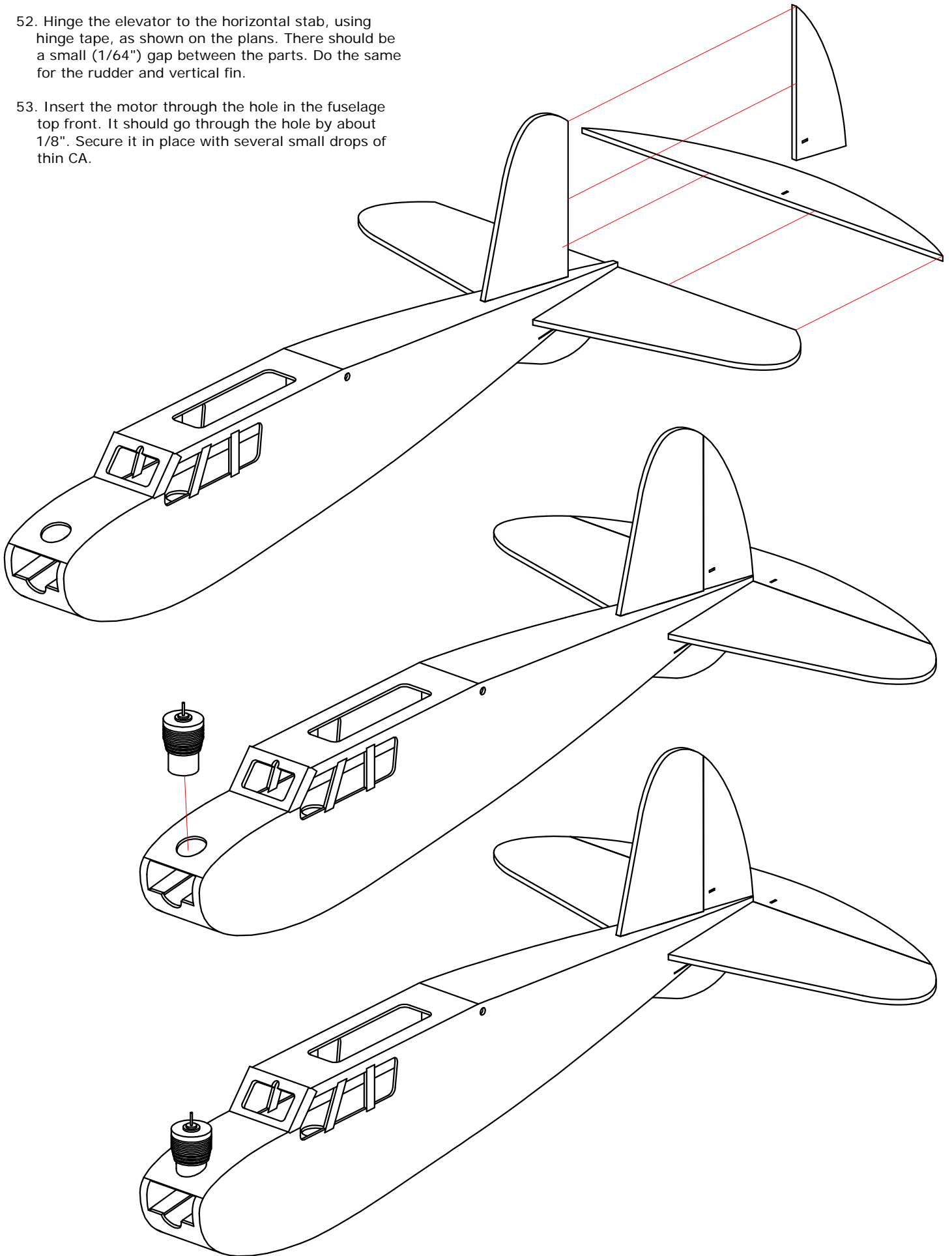

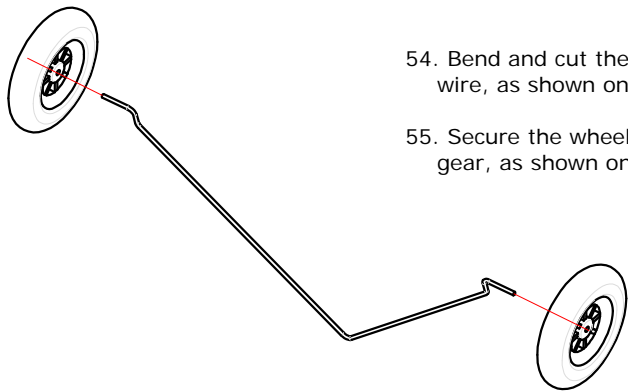

54. Bend and cut the landing gear wire, as shown on the plans.

55. Secure the wheels to the landing gear, as shown on the plans.

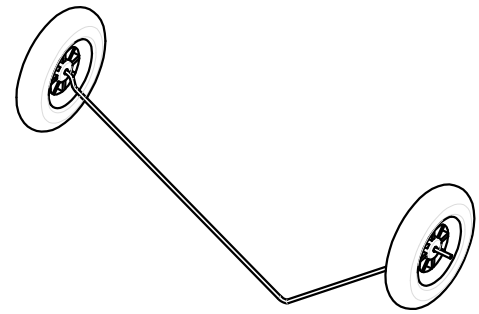

56. Press the landing gear into the slot on the fuselage bottom. Press in the landing gear retaining part, F18. You can use thin CA to glue in the retainer, if you do not want to remove the landing gear later on.

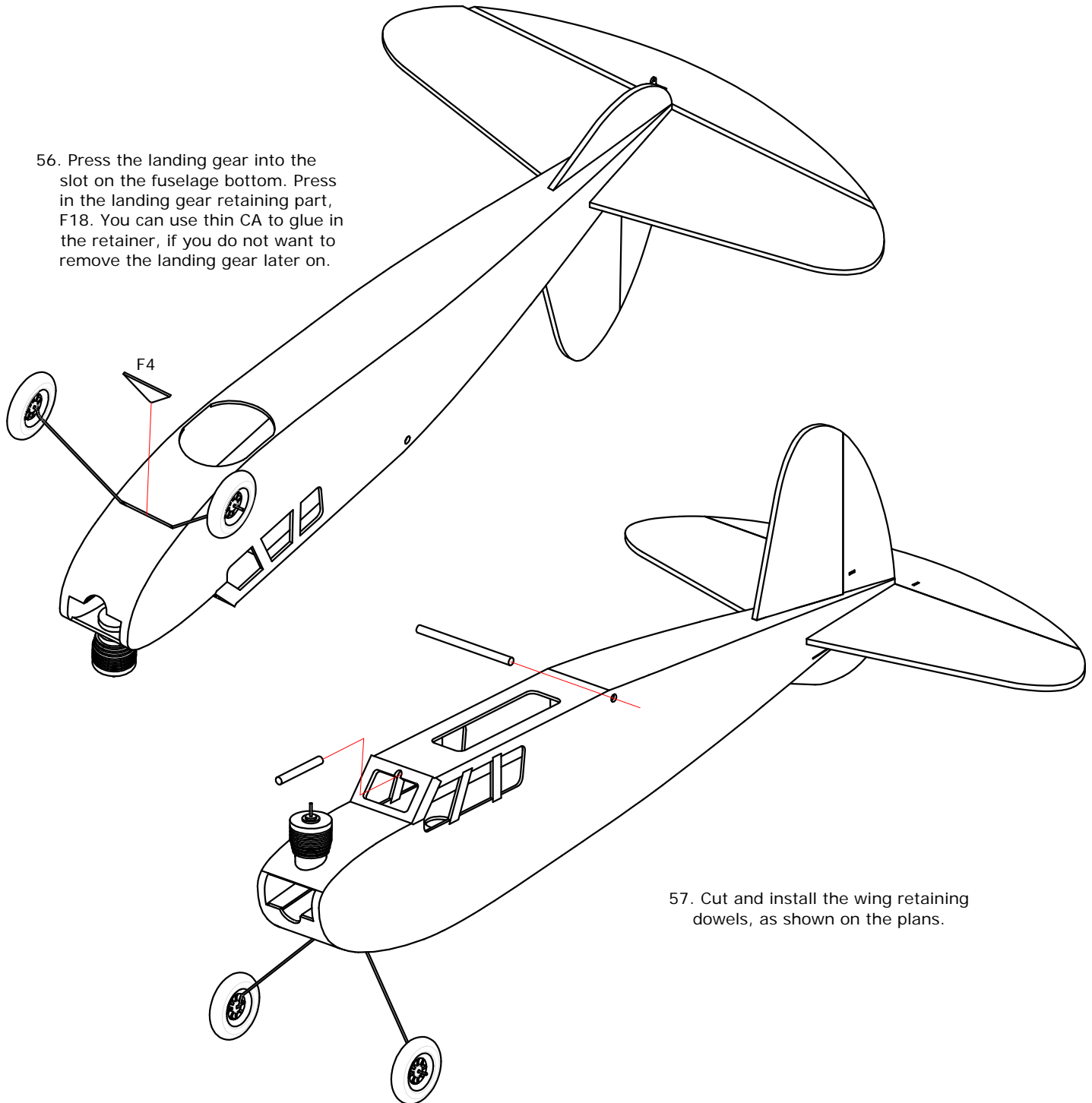

57. Cut and install the wing retaining dowels, as shown on the plans.

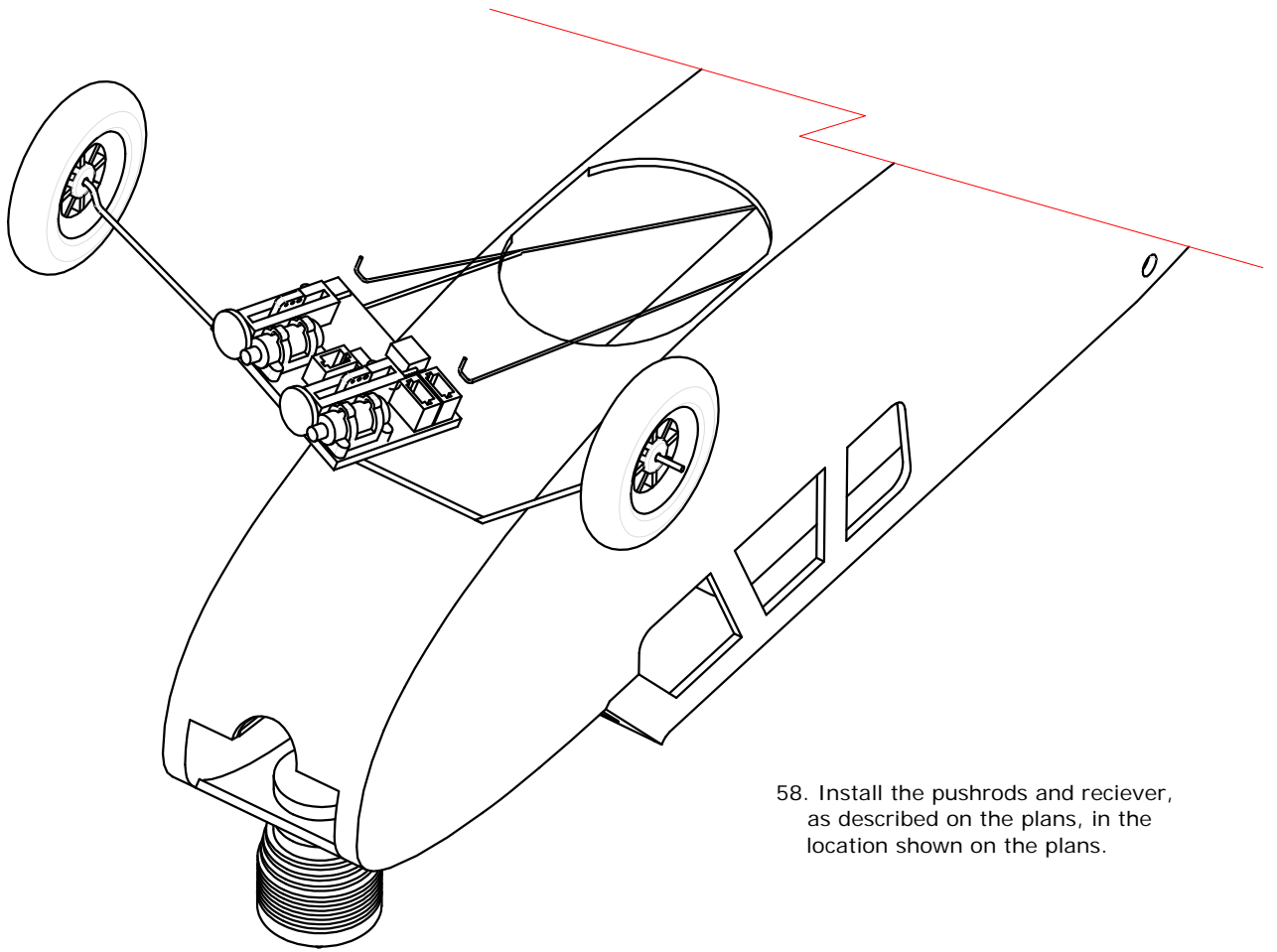

58. Install the pushrods and receiver, as described on the plans, in the location shown on the plans.

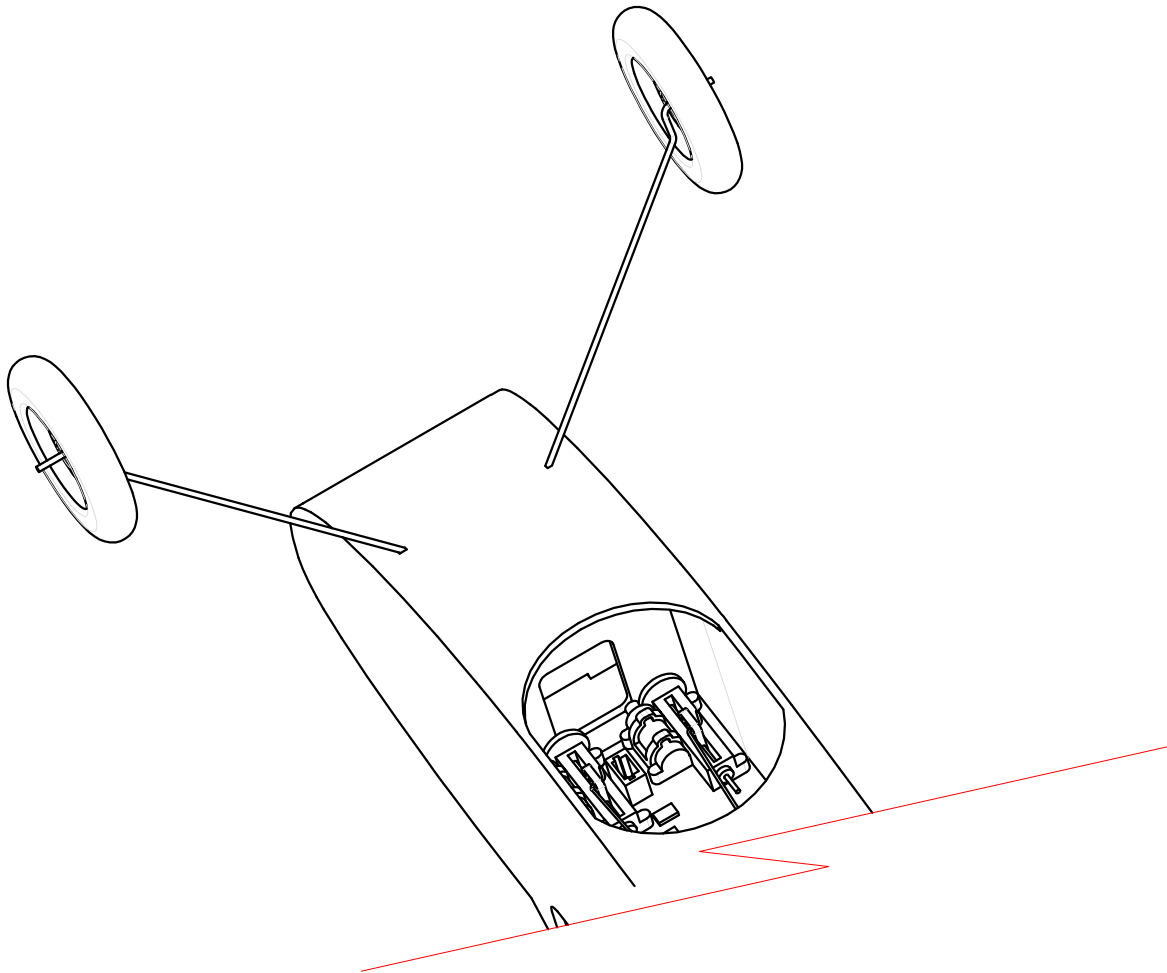

59. Glue the plywood control horns into the rudder and elevator with thick CA, as shown here and on the plans.

60. Follow the directions on page 2 of the plans to create and install the Z-Bend ends on the pushrods.

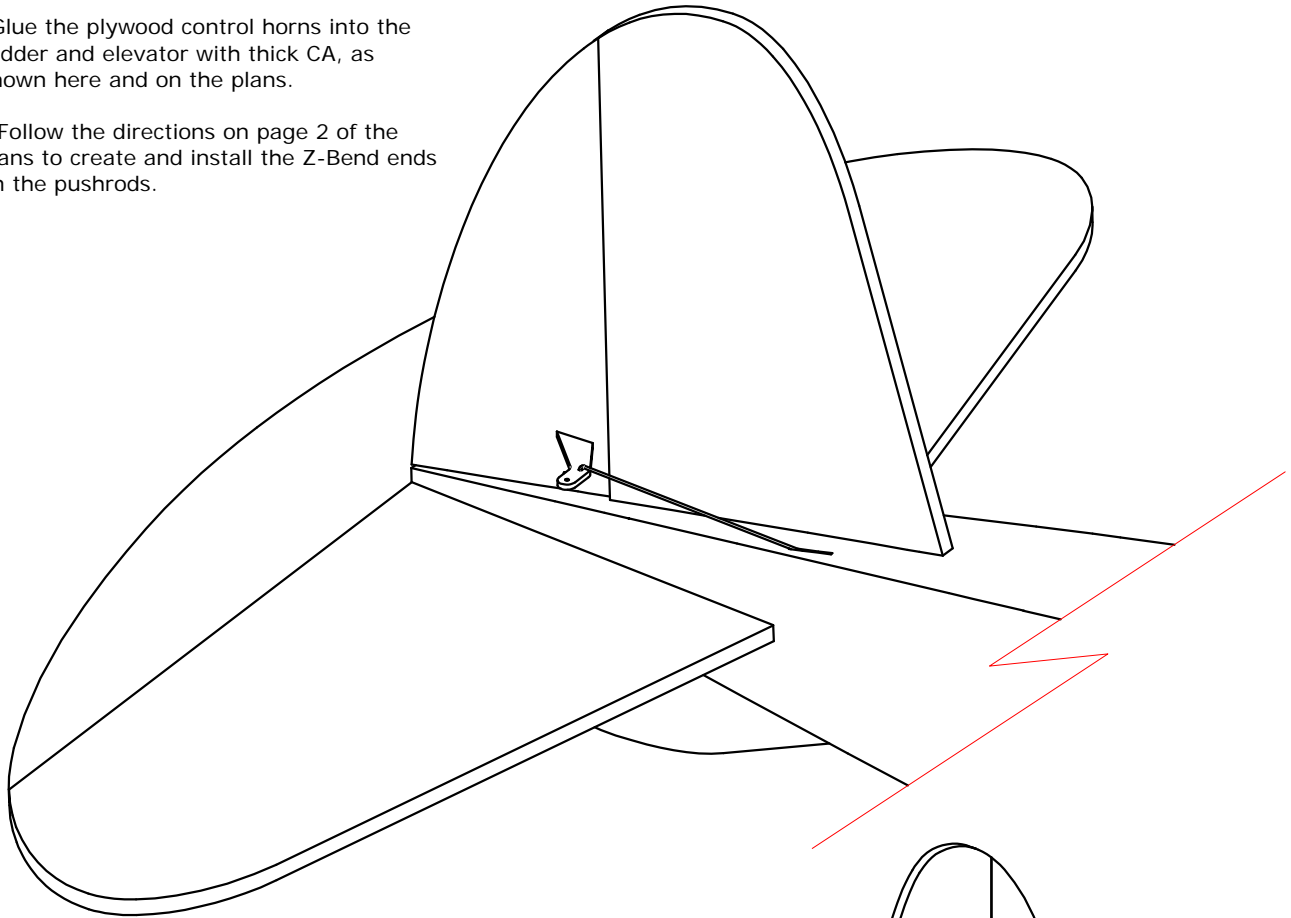

61. Trim the mounting "posts" off the gearbox and glue the motor/gearbox in place, using a couple drops of thick CA. The motor will have slight RIGHT thrust, once installed.

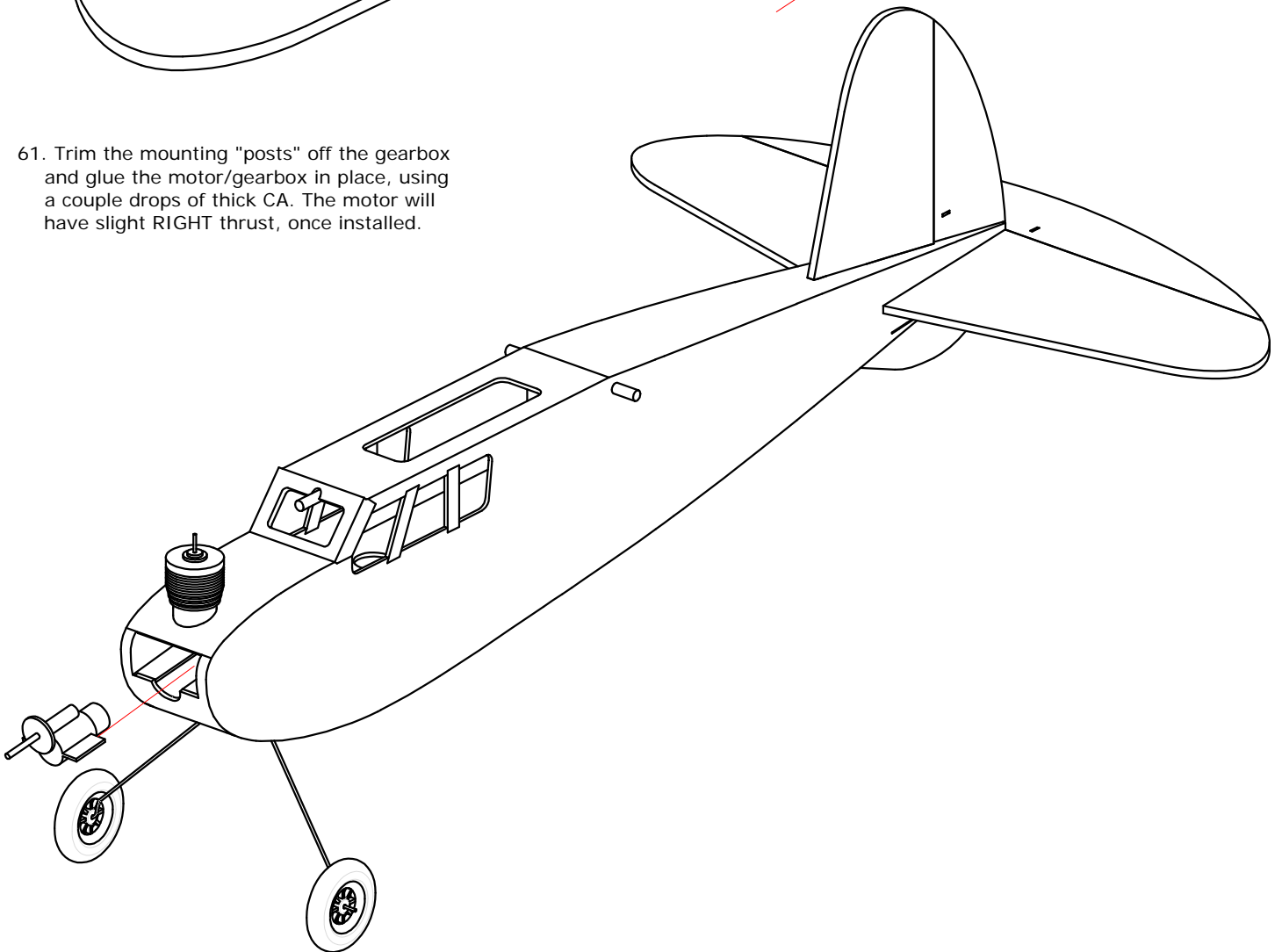

62. Hook up your motor wires to the RX, secure the battery to a fuselage side with Velcro, mount the wing with 4 rubber bands, and balance the model where it is shown on the plans.

63. DOUBLE CHECK your wings for any warps. If the wing is warped, straighten it out BEFORE trying to fly your model.

64. Use about 1/2 throttle and a gently hand launch for your first flight. Trim it out, if needed, and enjoy your SpookE Micro!

